



1000 Series

High Pressure Filters



High Pressure Filters

1000 Series

Features/Applications for High Pressure Hydraulic Filters 1000 Series

- Pressures to 6,000 PSI
- Flows to 265 GPM
- Microglass Elements 3 to 20 Micron
- 1½" and 2" Ports - SAE O-Ring or Code 62 Flange
- Reverse Flow Option

Specifications:

Flow Rating: 265 GPM

Operating Pressure: 6000 PSI

Proof Pressure: 9000 PSI

Burst Pressure: 12,000 PSI

Fatigue Pressure:

0-4000-0 PSI@3,000,000 cycles

Bypass Setting: 100 PSID

Fluid Temperature: -40°F to +212°F

Construction:

Head and Cap: Nodular Iron

Bowl: Seamless Steel Tube

Indicators: Brass

Elements: Consult Factory

Weight:

Length 1 -84 Lbs.

Length 2 -104 Lbs.

Electrical Ratings:

Hirschman Connector without Lamps:

T - 110 VAC, .5 Amp Ind., 2 Amp Res.

- 250 VAC, .5 Amp Ind., 2 Amp Res.

- 28 VDC, 1 Amp Ind., 2 Amp Res.

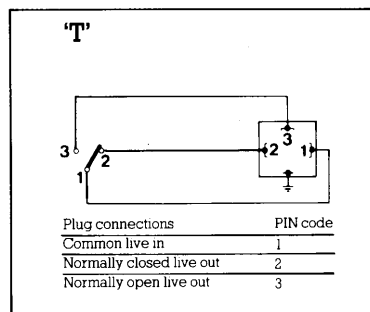

Dimensions Inches (mm)

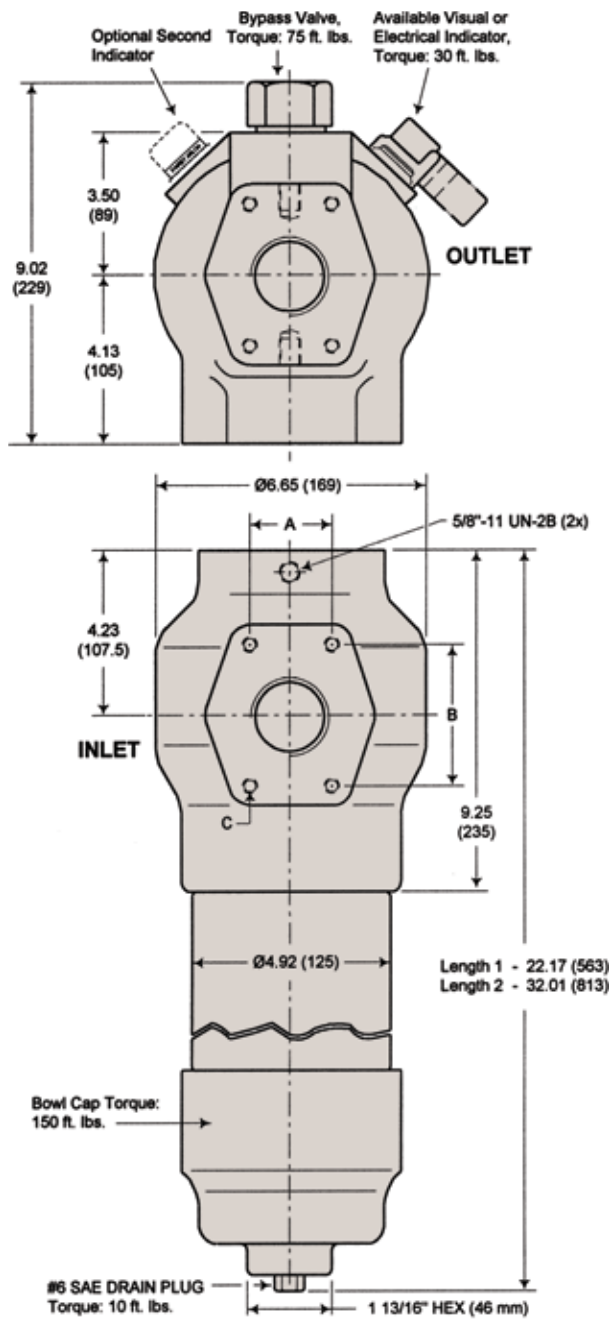

Optional Mounting Bracket

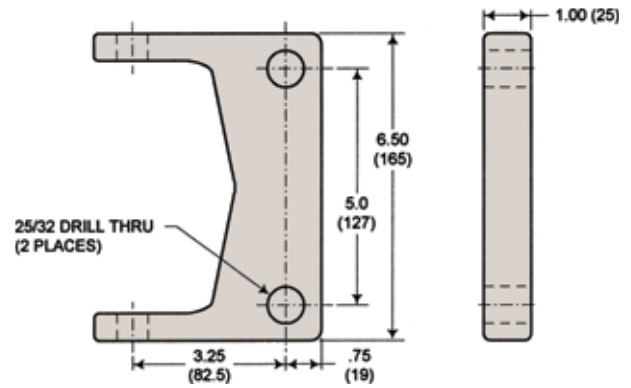

Port	Dimensions		
	A	B	C
F	1.437" 36.5mm	3.125" 79.4mm	5/8"-11 X 1.4"
T	1.750" 44.5mm	3.812" 96.8mm	3/4"-10 X 1.4"

Element Removal Clearance: Length 1 - 13.30
Length 2 - 23.10

High Pressure Filters

1000 Series

Flow/Pressure Drop Data

Fluid Conditions: Viscosity 140 SSU and Sp. Gr. 0.88

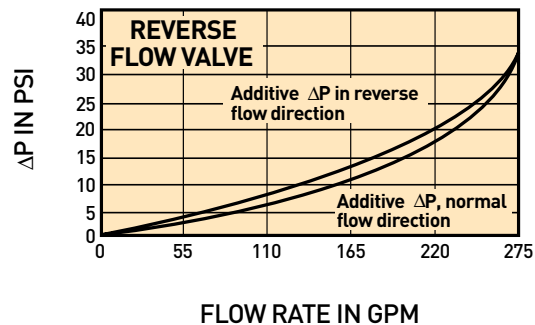
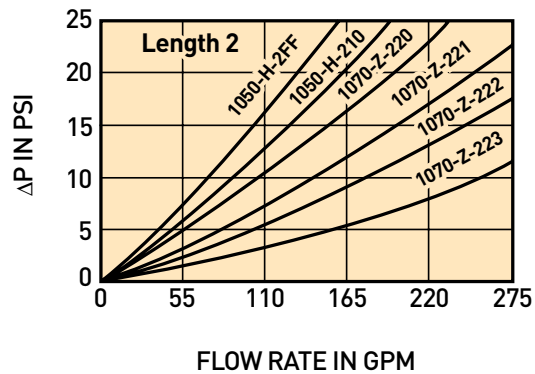
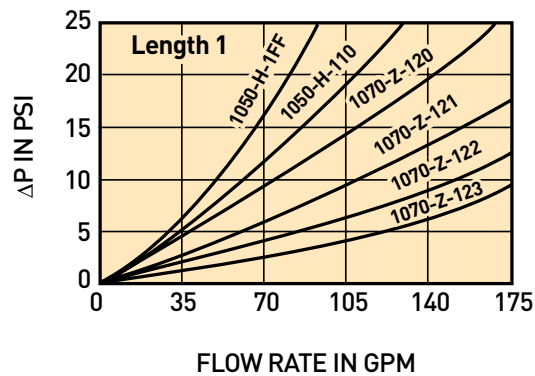
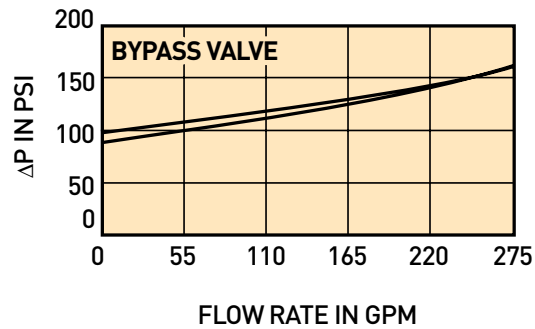
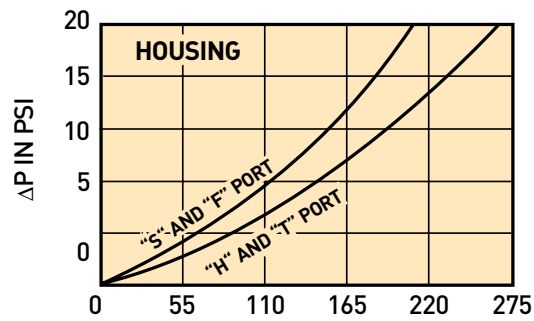

Multipass Test Results to ISO 4572 (Time Weighted Average)

Media Code	Filtration Rating						
	$\beta_{x \geq 100}$	β_3	β_6	β_{10}	β_{12}	β_{20}	β_{25}
20	3	≥ 100 99.0	> 300 99.67	> 1500 99.93	> 2000 99.95	> 5000 99.98	INF
21	6	12 91.7	≥ 100 99.0	> 1000 99.9	> 2000 99.95	> 5000 99.98	INF
22	10	8 87.5	22 95.4	≥ 100 99.0	≥ 200 99.5	> 5000 99.98	INF
23	20	-	2 50.0	8 87.5	20 95.0	≥ 100 99.0	> 200 99.5

Element Beta ratio β_x
Element efficiency in percent*

Parts Breakdown 1000 Series

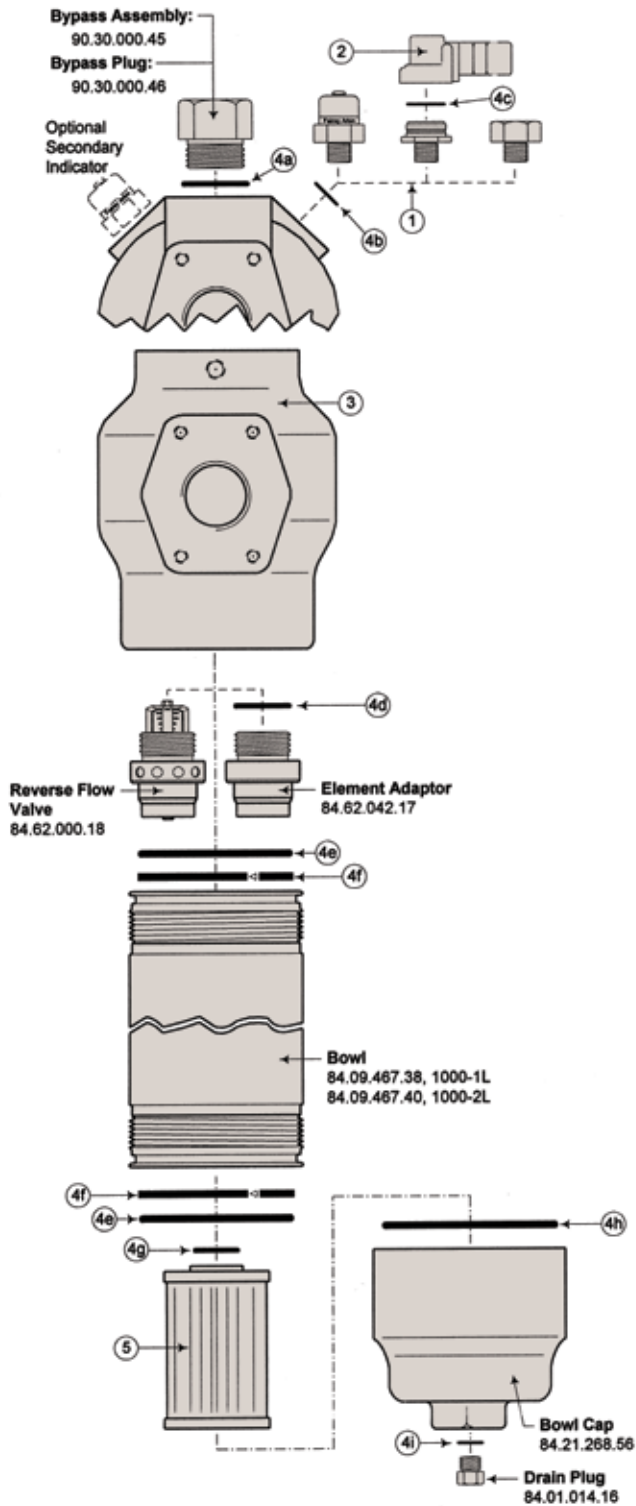

1 Indicators		
Visual	Electrical Sub-Assy	Indicator Plug
6N50-2A	90.34.000.24	84.01.066.30

2 Electrical Actuator Assembly		
Hirschmann Connector		
Code	Part Number	Voltages Available
T	FF3468	28 VDC, 250 VAC Max.

3 Head	
Description	Part Number
1000-S, SAE-24 (1-7/8"-12 Thread)	84.69.268.16
1000-H, SAE-32 (2-1/2"-12 Thread)	84.69.268.18
1000-F, 1-1/2" SAE 6000 PSI Flange, Code 62	84.69.268.20
1000-T, 2" SAE 6000 PSI Flange, Code 62	84.69.268.22

4 Seals			
Description	Buna-N	Viton	
Ⓐ Bypass Assy/Plug Seal*	N93924	V93924	
Ⓑ Indicator to Head Seal*	N72019	V72019	
Ⓒ Actuator Dust Seal	N72021		
Ⓓ Adaptor to Head Seal*	81.10.150.15	81.10.152.15	
Ⓔ Head/Bowl/Cap Seal*	N92346	V92346	
Ⓕ Head to Bowl Back-Up Ring	FF3142		
Ⓖ Element Seal	N72141	V72141	
Ⓗ Bowl Cap Seal*	81.10.150.86	81.10.152.86	
Ⓘ Drain Plug Seal*	N93906	V93906	

5 Element Kit‡				
Disposable All Fluids				
Length	3 µm abs.	6 µm abs.	10 µm abs.	20 µm abs.
1	1070-Z-120	1070-Z-121	1070-Z-122	1070-Z-123
2	1070-Z-220	1070-Z-221	1070-Z-222	1070-Z-223
High Collapse Disposable (3000 psid)				
Length	3 µm absolute		15 µm absolute	
1	1050-H-1FF		1050-H-110	
2	1050-H-2FF		1050-H-210	

*Included in Seal Kit: **936063**, Nitrile **936064**, Fluorocarbon

‡Included in Element Kit

‡To specify seal material, add the following suffix to the part number:
A Nitrile **H** Fluorocarbon

Options (Not Shown)	
Part Number	Description
402904	Mounting Bracket, Includes (2) 5/8"-11 x 1-1/4" Hex Flange Bolts

High Pressure Filters

1000 Series

HOW TO ORDER:

Select the desired symbol (in the correct position) to construct a model code.

Example:

	BOX 1	BOX 2	BOX 3	BOX 4	BOX 5	BOX 6	BOX 7	BOX 8	BOX 9
10	7	4	A	2HN70	S	Z	1	23	TP

Element Example:

	BOX 1		BOX 6	BOX 7	BOX 8	BOX 3
10	7	0	Z	1	23	A

BOX 1: FILTER/ELEMENT TYPE	
Symbol	Description
5	Microglass High Strength Disposable
7	Microglass Inorganic Disposable

BOX 2: FILTER FLOW	
Symbol	Description
2	With Reverse Flow Valve
4	Normal Flow

BOX 3: SEAL CODE	
Symbol	Description
A	Nitrile
H	Fluorocarbon

BOX 4: INDICATOR TYPE		
Indicator Type	NO BYPASS INDICATION@ 73 PSID (5.0 BAR)	100 PSID BYPASS INDICATION@ 73 PSID (5.0 BAR)
Visual	4HN00	2HN70
Electrical (T) 28 VDC, 110-250 VAC	5HT00	3HT70

BOX 5: PORT OPTIONS	
Symbol	Description
F	SAE 6000 PSI 1-1/2" Flange (Code 62)
T	SAE 6000 PSI 2" Flange (Code 62)

Note: For Dual Indicator availability please consult Factory.

BOX 6: ELEMENT TYPE		
Element Types (with contained O-Ring)		Absolute Micron Ratings
Z	Suitable for all Conventional Hydraulic Fluids, except Phosphate Esters	3, 6, 10 and 20

BOX 7: ELEMENT LENGTH	
Symbol	Description
1	Single length
2	Double length

BOX 8: ELEMENT MEDIA		
Symbol	Description	Type
FF	2µm Microglass III, high strength	5
10	10µm Microglass III, high strength	5
20	2µm Microglass III	7
21	5µm Microglass III	7
22	10µm Microglass III	7
23	20µm Microglass III	7

BOX 9: OPTIONS	
Symbol	Description
TP	Mounting Bracket
OMIT	If not required