



272/372 Series

Reverse Flow Pressure Filters



Reverse Flow Pressure Filters

272/372 Series

Features/Applications for High Pressure Hydraulic Filters 272 Series

Pressures to 6,000 PSI	Disposable or Recleanable Elements
Flows to 65 GPM	
Microglass Elements - 3 to 20 Micron Absolute	Reverse Flow

Specifications High Pressure Hydraulic Filters - 200 Series

Flow Rating: 65 GPM

Pressure Rating:

Operating Pressure (Maximum)	6000 PSI
Proof Pressure	9000 PSI
Burst Pressure	12000 PSI
Fatigue Pressure (Maximum)	0-4000-0 PSI @3,000,000 Cycles

Fluid Temperature: -40°F to +212°F

Construction:

Head	Nodular Iron
Bowl	Extruded Steel
Indicators	Consult Factory
Elements	Consult Factory

Weight:	S.A.E. or Flange Ports	Manifold Ports	
	Length 1	20 Lbs.	24 Lbs.
	Length 2	22 Lbs.	26 Lbs.

Wiring Diagrams:

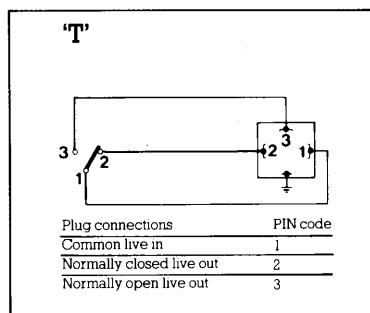

Electrical Ratings:

Hirschman Connector without Lamps:
 T - 250 or 110 VAC or 28 VDC Max.

High Performance New Generation 272 Series Filters

A rugged modular design for applications to 6000 PSI and 65 GPM. Parker's high pressure filters are specified worldwide for industrial, mobile, marine and mining applications.

Parker's high pressure filters are the finest you can buy. Here is why:

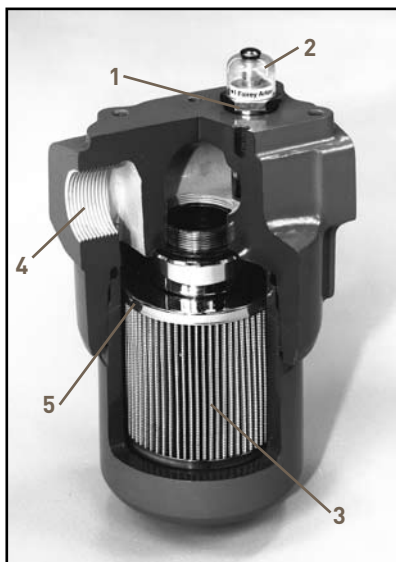

TruTell combined bypass valve and indicator.

1. High performance, low hysteresis bypass valve assures quick return to the closed position following cold starts or other short-term bypass conditions. Result: the best filter performance and protection for your system. The location of the bypass valve is 90° to the flow stream, which prevents unwanted valve operation and helps cushion the effect of system shocks (when compared with in-line valve location).
2. The bypass condition is indicated by the appearance of a red band under the transparent dome. The indicator has 360° visibility for easy viewing. Several other indicator options are shown below.

Microglass Media Offering

3. Microglass III represents a leap forward in the performance obtainable in hydraulic and lube filter elements. The unique multi-layer design combines high efficiencies with exceptional dirt holding capacities for performance that is unequalled in the industry today. With Microglass III, you do not have to make a compromise between efficiency and capacity; you can have both.

Other Features

4. Port options include SAE straight thread, SAE 3000 or 6000 PSI flanges or manifold mount.
5. Bowl-into-head assembly provides positive sealing and easier servicing.
6. A rugged, low pressure drop reverse flow valve is available.
7. For complete information, see design features section.



- (A) 272 Series length 2
 (B) 272 Series length 2 manifold mounting
 (C) 272 Series length 1 with visual latching indicator
 (D) 272 Series length 1 with dual electrical and visual indicators

TrueTell Bypass Valve/Clogging Indicator

Over 30 years of testing valves of different configurations led to the combined TruTell bypass valve and indicator. This design produces the best all around characteristics for stability, low hysteresis, minimal leakage and reliability.

A bypass valve that closes quickly and completely is important because a filter in bypass offers no system protection, especially from large particles that can cause catastrophic failure.

The TruTell bypass valve and indicator assembly is a precision machined design from which hysteresis effects have been virtually eliminated. See curve.

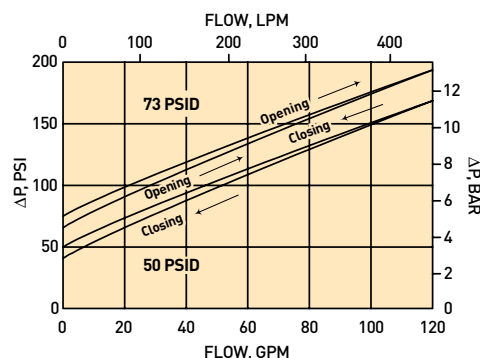

Reverse Flow Pressure Filters

272/372 Series

Point 1

Competitive bypass valve designs with significantly different areas between the open and closed position or high friction sliding seals have high hysteresis. As a result these bypass valves do not close as quickly as they should and a large percentage of the fluid continues to bypass the filter element completely after a cold start up (usually anything below 68°F).

Point 2

Most competitive bypass valves dramatically limits filter assembly performance even with a good element in the filter housing. The TruTell design forces as much fluid as possible through the element even when partially open.

Point 3

The TruTell bypass valve location is very important. Our valve and indicator combination is situated near the outlet port at right angles to the flow path. In this position it monitors only element differential pressure. Undesirable leakage and premature bypass associated with in line valve locations are eliminated. This location also helps cushion the effect of system shocks that pass through in-line bypass valves virtually unaffected.

Point 4

Our TruTell Bypass valve is magnetically coupled to the indicator. This assures no false warning that element bypass will ever occur. If the indicator actuates, an impending or bypass condition exists period. Unless the indicator is coupled to the bypass valve, it is impossible to accurately indicate bypass valve position under all operating conditions.

Point 5

Parker offers the widest selection of indicator types in the industry.

Visual types include:

- A. A 360° visibility non-latching type
- B. A 360° visibility latching type (For remote locations or flow on demand systems, or where systems must be shut down to inspect the filter.)

Electrical indicators include:

- C. Visual electrical
- D. Electrical and Visual
- E. Dual electrical

For electrical indicator connector options see Box 4 on page 126.

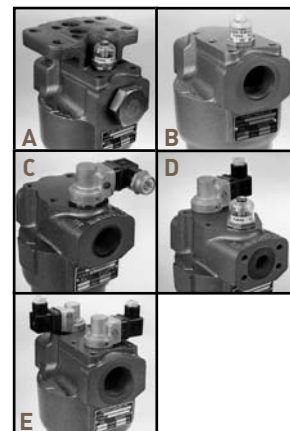

Microglass Media High Performance

Multi-Pass Test Results to ISO 4572 (Time Weighted Average)

Filter Type	Media	Code	Filtration Rating							
			$\beta_x > 200$	β_3	β_6	β_{10}	β_{12}	β_{20}	β_{25}	
5	300psi High Collapse	02QX	FF	3	≥ 200 99.5	> 1000 99.9	> 3000 99.97	> 5000 99.98	INF	INF
		10QX	10	15	3 66.66	12 91.66	50 98.0	75 98.67	> 2000 99.95	> 5000 99.98
Filter Type	Media	Code	Filtration Rating							
			$\beta_x > 200$	β_3	β_6	β_{10}	β_{12}	β_{20}	β_{25}	
7	290psi Collapse	GDH3	20	3	≥ 100 99.0	> 300 99.67	> 1500 99.93	> 2000 99.95	> 5000 99.98	INF
		GDH6	21	6	12 91.7	≥ 100 99.0	> 1000 99.9	> 2000 99.95	> 5000 99.98	INF
		GDH10	22	10	8 87.5	22 95.4	100 99.0	≥ 200 99.5	> 5000 99.98	INF
		GDH20	23	20	-	2 50.0	8 87.5	20 95.0	≥ 100 99.0	≥ 200 99.5

Element efficiency in percent
Element Beta ratio B_x

Flow/Pressure Drop Curves

Disposable Elements - 272 Series

For Bypass Equipped Housings (290 psid min. collapse)

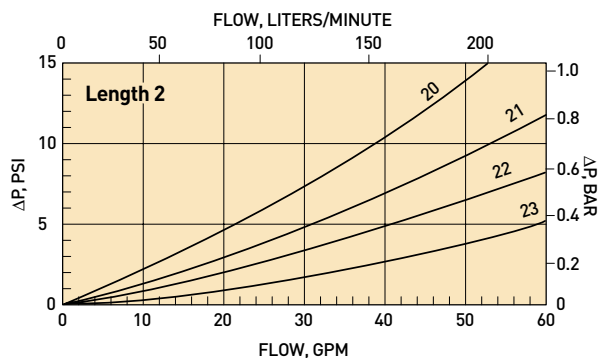
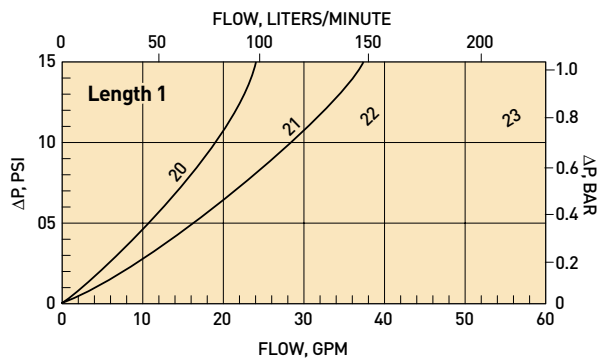

For Non-bypass Housings (3000 psid min. collapse)

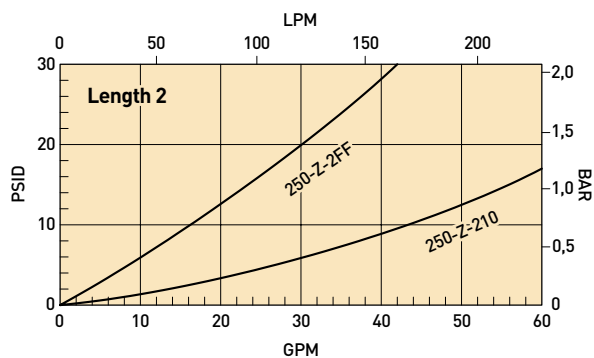
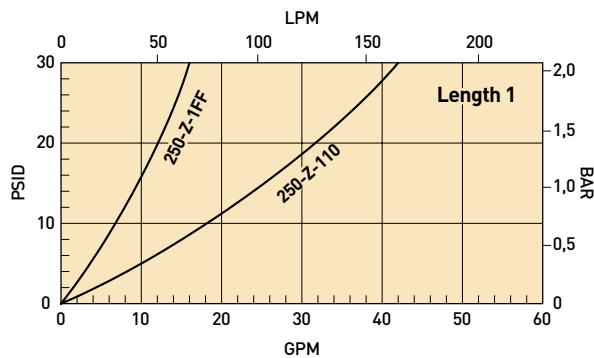

Fluid Conditions: Viscosity 140 SSU (30 cSt) and Sp. Gr. 0.88

Note: Element ΔP is directly proportional to viscosity.

Find Filter Assembly Pressure Drop

Filter assembly ΔP is equal to the sum of element and housing pressure drops taken from the appropriate curves and adjusted for operating viscosity and specific gravity.

Example:

Filer Model: 272A-BV50-JZ222

Flow: 50 GPM

Viscosity: 225 SSU, Sp. Gr.: 1.0

Step 1. Correct element ΔP for viscosity.

Element ΔP = 6 psi x 225SSU/140SSU = 9.6psi

Step 2. Correct housing ΔP for specific gravity.

Housing ΔP = 15 psi x 1.0/0.88 = 17.0 psi

Step 3. Correct reverse flow

Valve ΔP for specific gravity

RFV ΔP = 4 psi x 1.0/0.88 = 4.5 psi

Step 4. Calculate assembly

ΔP = 9.6 psi + 17.0 psi + 4.5 psi = 31.1 psi

NOTE: Housing and reverse flow valve ΔP are directly proportional to specific gravity.

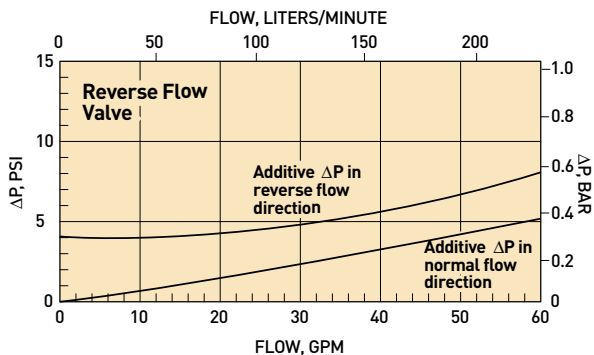
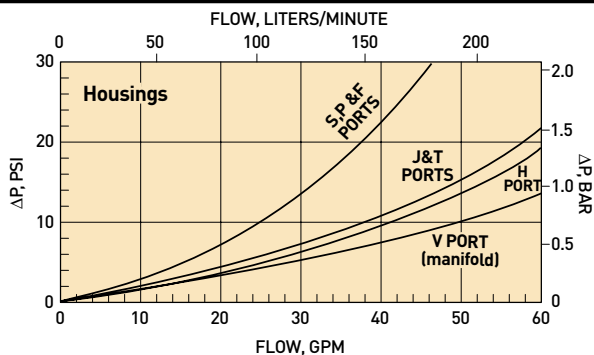

Reverse Flow Pressure Filters

272/372 Series

Dimensions

Inches (mm)
272 Series

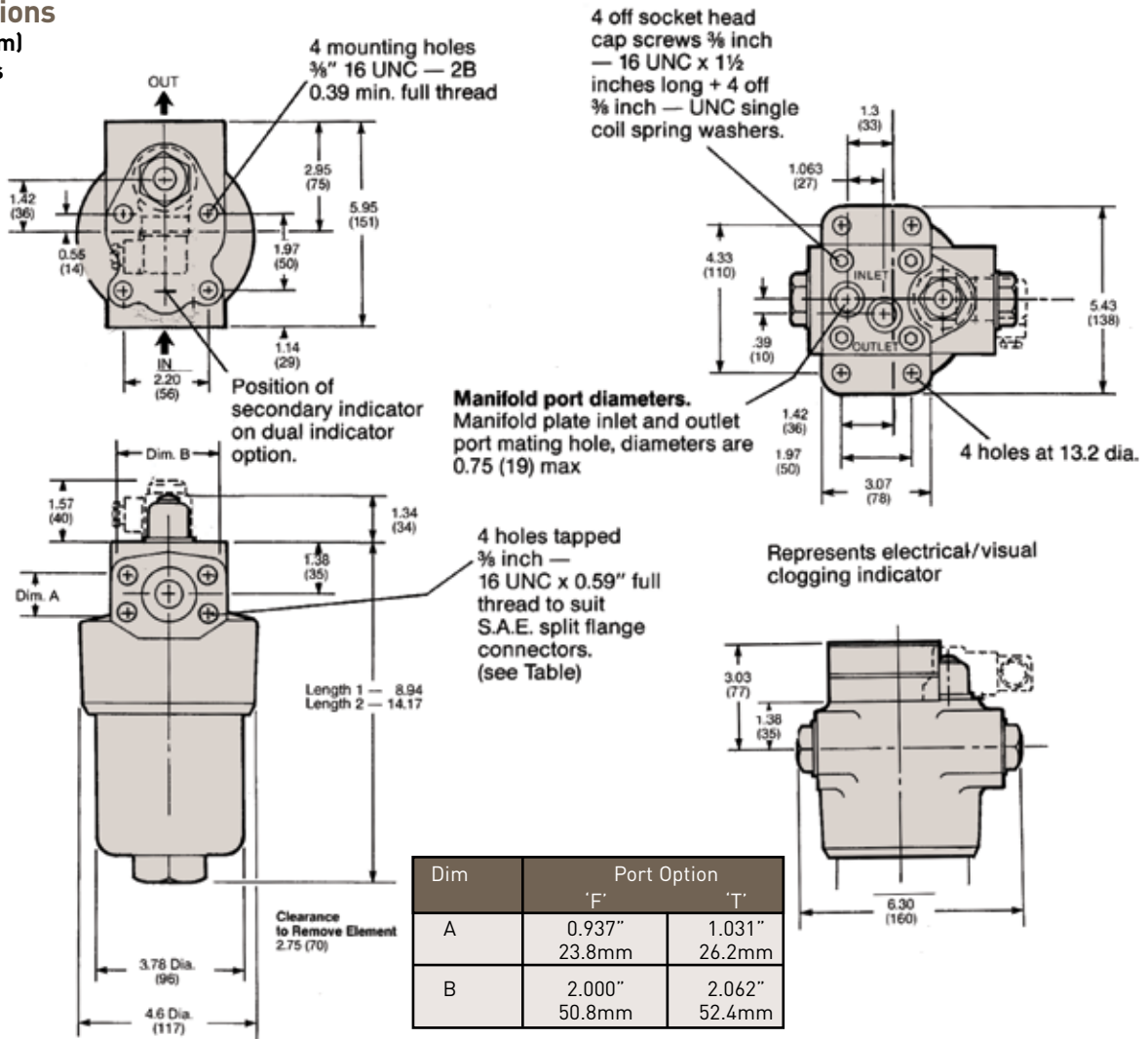

Reverse Flow Valve Better Three Ways

For hydrostatic drives and other systems where reverse flow is required a valve is incorporated which allows fluid to pass through the element in one direction but to bypass the element when flow is reversed. (See diagrams).

1. Rugged one piece steel body design that is built to last. Unlike stamped metal or aluminum designs. Parker's Reverse Flow Valve (RFV) is a spool/disc valve caged in a high strength machined steel body. This greatly reduces the risk of valve failure and resultant filter or component damage.
2. Low pressure drop the spool/disc design keeps system pressure losses at a minimum without sacrificing reliability.
3. Our modular design means easy change over or replacement. The reverse flow valve threads directly into the filter head, replacing the standard element adapter. For customers with more than one application or for system conversions, multiple applications from the same hardware means less inventory.

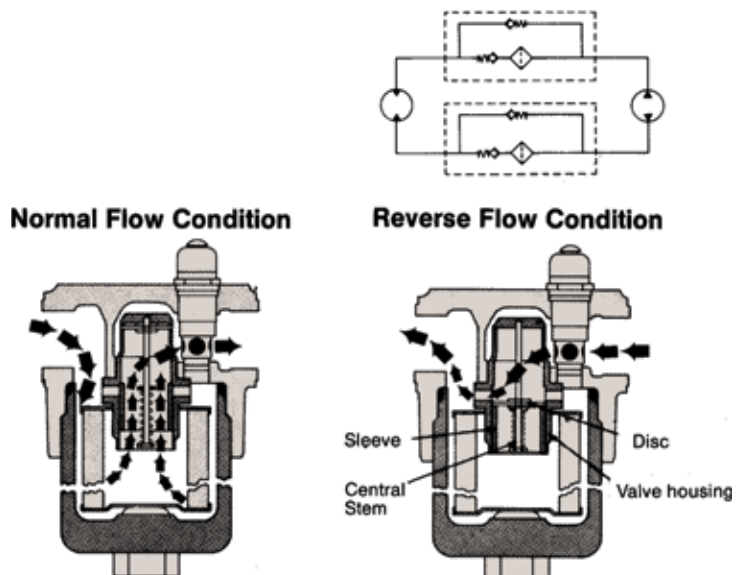

Reverse Flow Pressure Filters

272/372 Series

Parts Breakdown 272 Series Filter

Visual Indicator Assembly	
Bypass Valve	No Bypass Valve
BV50-2	NV50-2
Latching	Latching
BL50-2	NL50-2

Non-Indicator Assembly	
Non-Bypass Plug	Bypass Assy.
"—"	BN50-2

Electrical Actuator Assembly Hirschmann Connector		
Code	Part Number	Voltages Available
T	FF3468	28 VDC, 250 VAC Max.

Electrical Subassembly	
Bypass Valve	Non-Bypass
90.34.000.29 (73 psid)	90.34.000.27 (73 psid)
90.34.000.28 (50 psid)	90.34.000.26 (50 psid)

HEAD	
Description	Part Number
SAE-12 (1 ¹ / ₁₆ " 12 Thread)	204-S
SAE-16 (1 ⁵ / ₁₆ " 12 Thread)	204-J
SAE-20 (1 ⁵ / ₈ " 12 Thread)	204-H
SAE 6000 PSI 3/4" Flange, Code 62	204-F
SAE 3000 PSI 1" Flange, Code 61	204-T
Manifold Adapter	204-V

Element Kit				
Length	Disposable All Fluids			
	3 μm abs.	6 μm abs.	10 μm abs.	20 μm abs.
1	270-Z-120	270-Z-121	270-Z-122	270-Z-123
2	270-Z-220	270-Z-221	270-Z-222	270-Z-223
High Collapse Disposable (3000 psid)				
		3 μm absolute	15 μm absolute	
1		250-Z-1FFH	250-Z-110H	
2		250-Z-2FFH	250-Z-210H	
High Collapse Cleanable (3000 psid)				
		6 μm absolute	20 μm absolute	
1		240-Z-101	240-Z-110	
2		240-Z-201	240-Z-210	
Cleanable				
		40 μm absolute	75 μm absolute	
1		290-Z-140	290-Z-175	
2		290-Z-240	290-Z-275	

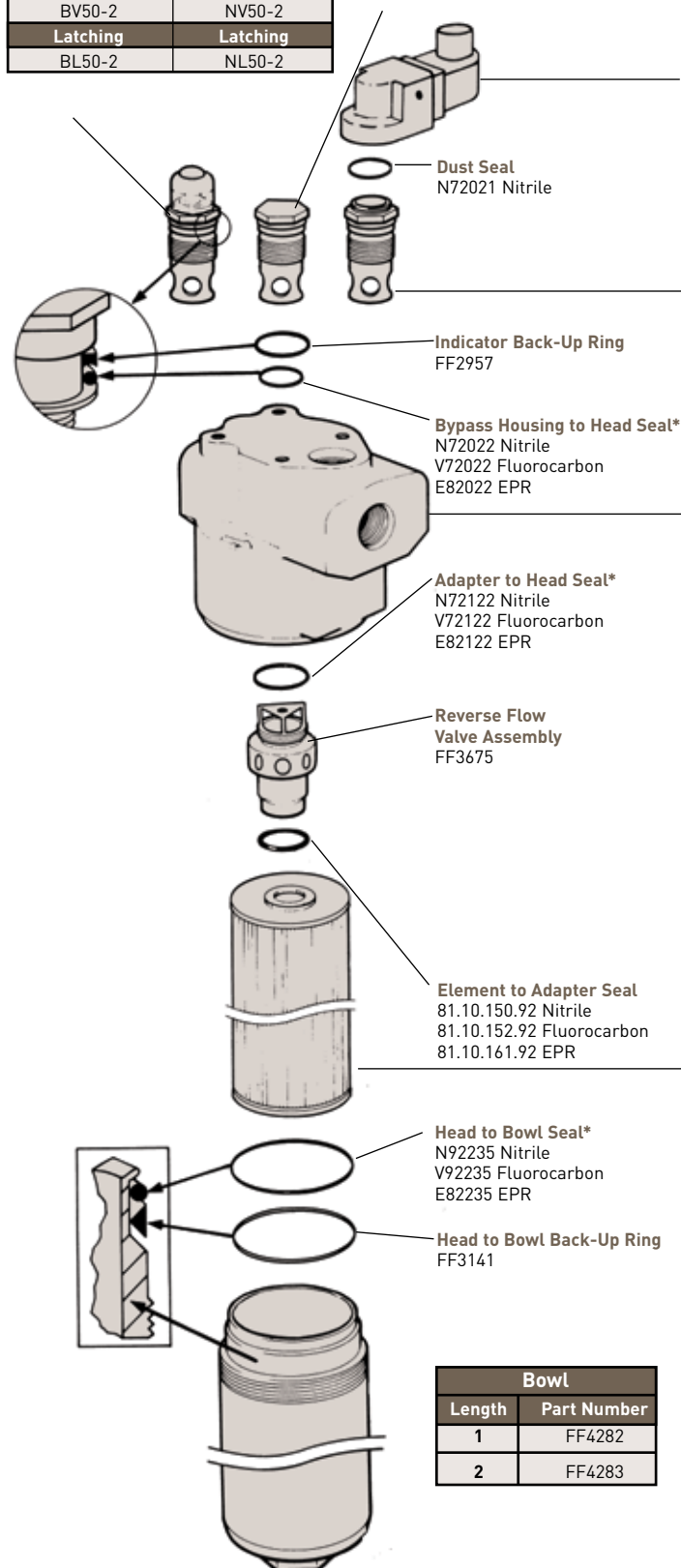

*Included in Seal Kit: 936057 Nitrile
936058 EPR
936059 Fluorocarbon

Reverse Flow Pressure Filters

272/372 Series

HOW TO ORDER 272 Series Filters:

Select the desired symbol (in the correct position) to construct a model code.

Assembly Example:

STD	BOX 1	BOX 2	BOX 3	BOX 4	BOX 5	BOX 6	BOX 7	BOX 8
2	7	2	A	BV50	S	Z	1	23

Element Example:

STD	BOX 1	STD	BOX 6	BOX 7	BOX 8	BOX 3
2	7	0	Z	1	23	A

BOX 1: FILTER/ELEMENT TYPE	
Symbol	Description
7	Microglass Inorganic disposable
5	High Strength Disposable

BOX 2: FILTER FLOW	
Symbol	Description
2	With Reverse Flow Valve

BOX 3: SEALS	
Symbol	Description
A	Nitrile
H	Fluorocarbon

BOX 4: INDICATOR		
Indicator Type	BYPASS	NO BYPASS
	INDICATION @ 73 PSID (5.0 BAR)	INDICATION @ 73 PSID (5.0 BAR)
VISUAL	BV50	NV50
VISUAL-LATCHING	BL50	-
ELECTRICAL (T) 28 VDC, 110-250 VAC	BE50	NE50

BOX 5: PORT OPTIONS		
Symbol	Description	Filter Ser.
S	SAE-12 (1-1/16"-12 Thread)	2
J	SAE-16 (1-5/16"-12 Thread)	2
H	SAE-20 (1-5/8"-12 Thread)	2
F	3/4" SAE Flange, Code 62	2
T	1" SAE Flange, Code 61	2
V	Manifold Adaptor	2

Dual Indicator Codes:

BEE50 - Bypass with double electrical indicators

NEE50 - No bypass with double electrical indicators

BEV50 - Bypass with (1) mechanical visual (50 psid) and (1) electrical indicator (73 psid)

NEV50 - No bypass with (1) mechanical visual (50 psid) and (1) electrical indicator (73 psid)

Note: Dual Indicators are not available with Port Option "V"

BOX 6: ELEMENT TYPE		
Symbol	Element Types	Absolute Ratings Micron
Z	All fluids	All ratings

BOX 7: ELEMENT LENGTH		
Symbol	Description	Type
1	Length 1	5, 7
2	Length 2	5, 7

BOX 8: DEGREE OF FILTRATION		
Symbol	Absolute Rating	Type
FF	3μ	5
10	15μ	5
20	3μ	7
21	6μ	7
22	10μ	7
23	20μ	7

Applications/Features for High Pressure Hydraulic Filters 372 Series

Pressures to 6,000 PSI
 Flows to 120 GPM
 BetaMaze™ Elements - 3 to 20 Micron Absolute
 Disposable or Recleanable Elements
 Reverse Flow

Specifications

High Pressure Hydraulic Filters — 372 Series

Max Flow Rating: 120 GPM
Pressure Rating:
 Operating Pressure (Maximum) 6000 PSI
 Proof Pressure 9000 PSI
 Burst Pressure 12000 PSI
 Fatigue Pressure (Maximum) 0-4000-0 PSI @3,000,000 Cycles

Fluid Temperature: -40°F to +212°F

Construction:
 Head Nodular Iron
 Bowl Extruded Steel
 Indicators Consult Factory
 Elements Consult Factory

Weight:

	S.A.E. or Flange Ports	Manifold Ports
Length 1	31 Lbs.	36 Lbs.
Length 2	37.5 Lbs.	42.5 Lbs.
Length 3	44 Lbs.	49 Lbs.

Wiring Diagrams:

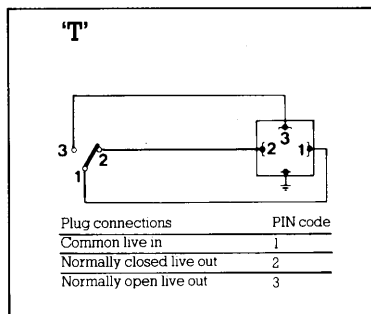

Electrical Ratings:

Hirschman Connector without Lamps:
 T - 250 or 110 VAC or 28 VDC Max.

Reverse Flow Pressure Filters

272/372 Series

High Performance New Generation 372 Series Filters

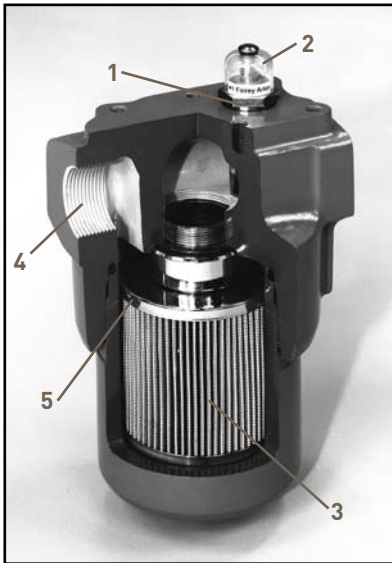

A rugged modular design for applications to 6000 PSI and 120 GPM. Parker's high pressure filters are specified worldwide for industrial, mobile, marine and mining applications.

Parker's high pressure filters are the finest you can buy. Here is why:

TruTell combined bypass valve and indicator.

1. High performance, low hysteresis bypass valve assures quick return to the closed position following cold starts or other short-term bypass conditions. Result: the best filter performance and protection for your system. The location of the bypass valve is 90° to the flow stream, which prevents unwanted valve operation and helps cushion the effect of system shocks (when compared with in-line valve location).
2. The bypass condition is indicated by the appearance of a red band under the transparent dome. The indicator has 360° visibility for easy viewing. Several other indicator options are shown below.

Microglass Media Offering

3. Microglass III represents a leap forward in the performance obtainable in hydraulic and lube filter elements. The unique multi-layer design combines high efficiencies with exceptional dirt holding capacities for performance that is unequalled in the industry today. With Microglass III, you do not have to make a compromise between efficiency and capacity; you can have both.

Other Features

4. Port options include SAE straight thread SAE 3000 or 6000 PSI flanges or manifold mount.
5. Bowl-into-head assembly provides positive sealing and easier servicing.
6. A rugged, low pressure drop reverse flow valve is available.
7. For complete information, see design features section.



- (A) 372 Series length 3
 (B) 372 Series length 3 manifold mounting
 (C) 372 Series length 1 with dual electrical and visual indicators
 (D) 372 Series length 2 with visual electrical indicator

TruTell Bypass Valve/Clogging Indicator

Over 30 years of testing valves of different configurations led to the combined TruTell bypass valve and indicator. This design produces the best all around characteristics for stability, low hysteresis, minimal leakage and reliability.

A bypass valve that closes quickly and completely is important because a filter in bypass offers no system protection, especially from large particles that can cause catastrophic failure.

The TruTell bypass valve and indicator assembly is a precision machined design from which hysteresis effects have been virtually eliminated. See curve.

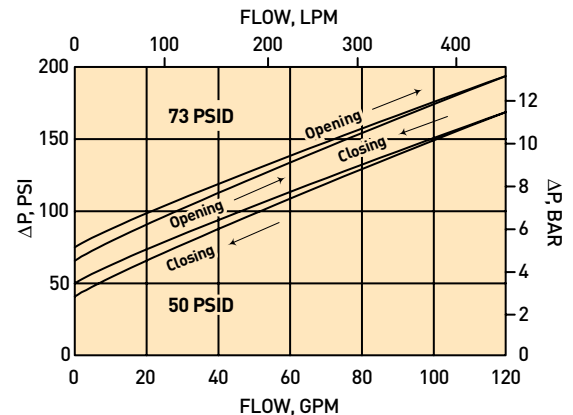

Point 1

Competitive bypass valve designs with significantly different areas between the open and closed position or high friction sliding seals have high hysteresis. As a result these bypass valves do not close as quickly as they should and a large percentage of the fluid continues to bypass the filter element completely after a cold start up (usually anything below 68°F).

Point 2

Most competitive bypass valves dramatically limits filter assembly performance even with a good element in the filter housing. The TruTell design forces as much fluid as possible through the element even when partially open.

Point 3

The TruTell bypass valve location is very important. Our valve and indicator combination is situated near the outlet port at right angles to the flow path. In this position it monitors only element differential pressure. Undesirable leakage and premature bypass associated with in line valve locations are eliminated. This location also helps cushion the effect of system shocks that pass through in-line bypass valves virtually unaffected.

Point 4

Our TruTell Bypass valve is magnetically coupled to the indicator. This assures no false warning that element bypass will ever occur. If the indicator actuates, an impending or bypass condition exists period. Unless the indicator is coupled to the bypass valve, it is impossible to accurately indicate bypass valve position under all operating conditions.

Point 5

Parker offers the widest selection of indicator types in the industry.

Visual types include:

- A. A 360° visibility non-latching type
- B. A 360° visibility latching type (For remote locations or flow on demand systems, or where systems must be shut down to inspect the filter.)

Electrical indicators include:

- C. Visual electrical
- D. Electrical and Visual
- E. Dual electrical

For electrical indicator connector options see Table 5 on back cover.

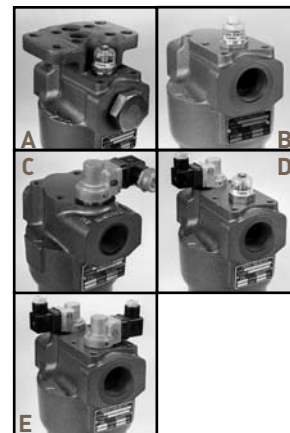

Microglass Media High Performance

Multi-Pass Test Results to ISO 4572 (Time Weighted Average)

Filter Type	Media	Code	Filtration Rating							
			$\beta_x > 200$	β_3	β_6	β_{10}	β_{12}	β_{20}	β_{25}	
5	300psi High Collapse	02QX	FF	3	≥ 200 99.5	> 1000 99.9	> 3000 99.97	> 5000 99.98	INF	INF
		10QX	10	15	3 66.66	12 91.66	50 98.0	75 98.67	> 2000 99.95	> 5000 99.98
Filter Type	Media	Code	Filtration Rating							
			$\beta_x > 200$	β_3	β_6	β_{10}	β_{12}	β_{20}	β_{25}	
7	290psi Collapse	GDH3	20	3	≥ 100 99.0	> 300 99.67	> 1500 99.93	> 2000 99.95	> 5000 99.98	INF
		GDH6	21	6	12 91.7	≥ 100 99.0	> 1000 99.9	> 2000 99.95	> 5000 99.98	INF
		GDH10	22	10	8 87.5	22 95.4	100 99.0	≥ 200 99.5	> 5000 99.98	INF
		GDH20	23	20	-	2 50.0	8 87.5	20 95.0	≥ 100 99.0	≥ 200 99.5

Element efficiency in percent
Element Beta ratio β_x

Reverse Flow Pressure Filters

272/372 Series

Flow/Pressure Drop Curves

Disposable Elements - 372 Series

For Bypass Equipped Housings (290 psid min. collapse)

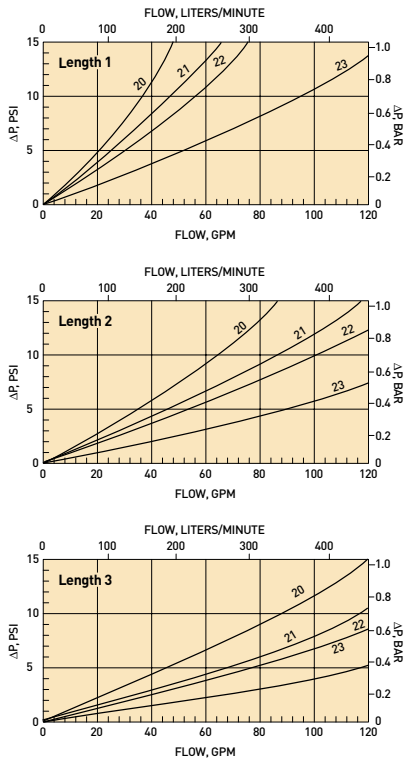

For Non-bypass Housings (3000 psid min. collapse)

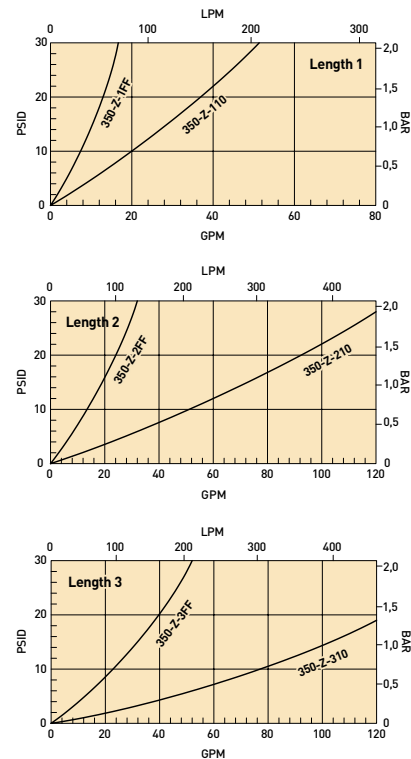

Fluid Conditions: Viscosity 140 SSU (30 cSt) and SP. Gr. 0.88

Note: Element ΔP is directly proportional to viscosity.

Find Filter Assembly Pressure Drop

Filter assembly ΔP is equal to the sum of element and housing pressure drops taken from the appropriate curves and adjusted for operating viscosity and specific gravity.

Example:

Filer Model: 372A-BV50-FL223

Flow: 120 GPM

Viscosity: 225 SSU, Sp. Gr.: 1.0

Step 1. Correct element ΔP for viscosity.

Element $\Delta P = 7 \text{ psi} \times 225\text{SSU}/140\text{SSU} = 11.2 \text{ psi}$

Step 2. Correct housing ΔP for specific gravity.

Housing $\Delta P = 27 \text{ psi} \times 1.0/0.88 = 30.7 \text{ psi}$

Step 3. Correct reverse flow valve ΔP for specific gravity.

RFV $\Delta P = 6 \text{ psi} \times 1.0/.88 = 6.8 \text{ psi}$

Step 4. Calculate assembly.

$\Delta P = 11.2 \text{ psi} + 30.7 \text{ psi} + 6.8 \text{ psi} = 48.7 \text{ psi}$

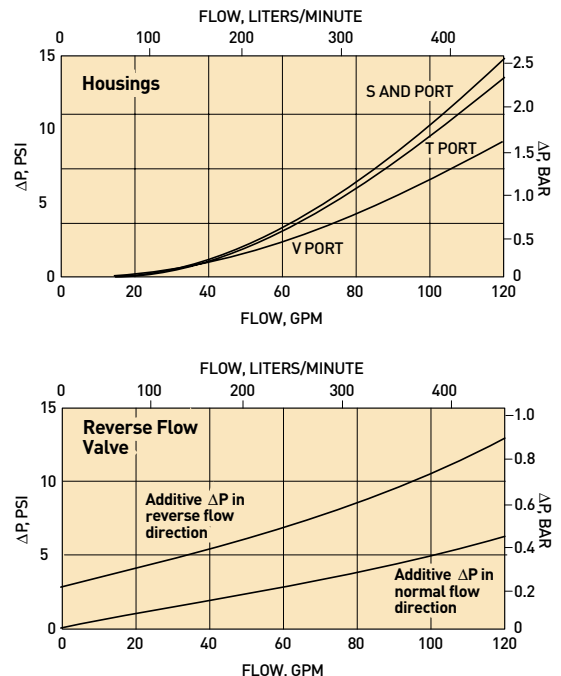

Dimensions

372 Series Inches (mm)

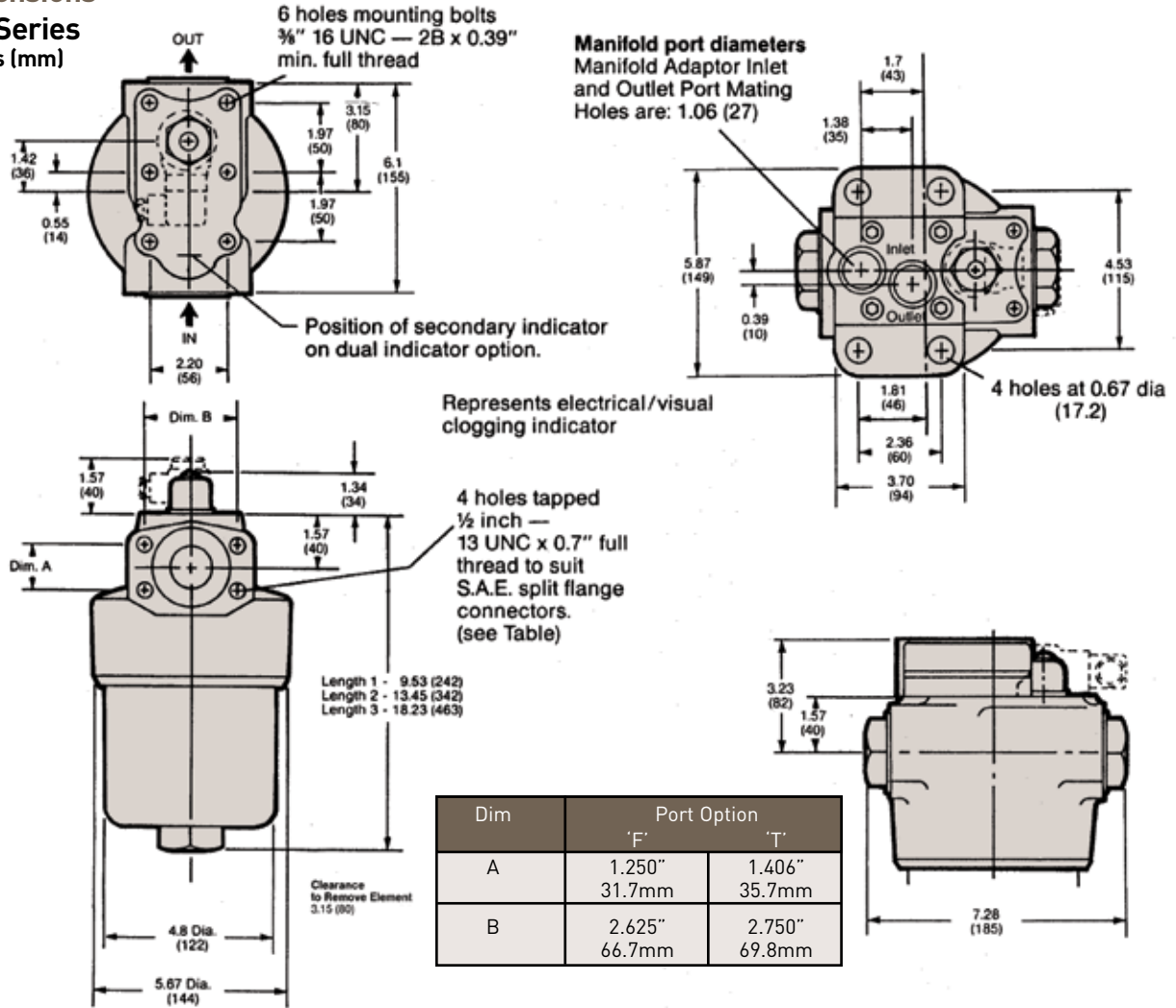

Reverse Flow Valve — Better Three Ways

For hydrostatic drives and other systems where reverse flow is required a valve is incorporated which allows fluid to pass through the element in one direction but to by-pass the element when flow is reversed. (See diagrams).

1. Rugged one piece steel body design that is built to last. Unlike stamped metal or aluminum designs, Parker's Reverse Flow Valve (RFV) is a spool/disc valve caged in a high strength machined steel body. This greatly reduces the risk of valve failure and resultant filter or component damage.
2. Low pressure drop — the spool/disc design keeps system pressure losses at a minimum without sacrificing reliability.
3. Our modular design means easy change over or replacement. The reverse flow valve threads directly into the filter head, replacing the standard element adapter. For customers with more than one application or for system conversions, multiple applications from the same hardware means less inventory.

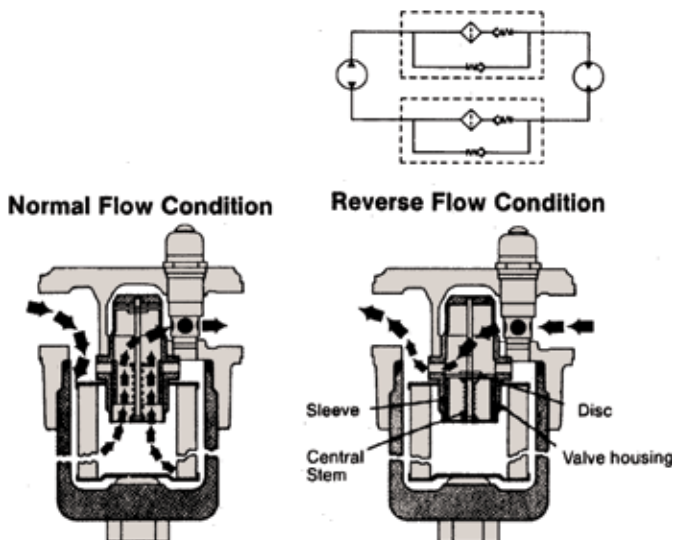

Reverse Flow Pressure Filters

272/372 Series

Filter Parts Breakdown 372 Series

Visual Indicator Assembly	
Bypass Valve	No Bypass Valve
BV50-2	NV50-2
Latching	Latching
BL50-2	NL50-2

Non-Indicator Assembly	
Non-Bypass Plug	Bypass Assy.
-	BN50-2

Electrical Actuator Assembly Hirschmann Connector		
Code	Part Number	Voltages Available
T	FF3468	28 VDC, 250 VAC Max.

ELECTRICAL SUBASSEMBLY	
Bypass Valve	Non-Bypass
90.34.000.29, 73 PSID	90.34.000.27, 73 PSID
90.34.000.28, 50 PSID	90.34.000.26, 50 PSID

Head	
Description	Part Number
SAE-20 (1 5/8" 12 Thread)	304-S
SAE 6000 PSI 1 1/4" Flange, Code 62	304-F
SAE 3000 PSI 1 1/2" Flange, Code 61	304-T
Manifold Adapter	304-V

Element Kit				
Length	Disposable All Fluids			
	3 μm abs.	6 μm abs.	10 μm abs.	20 μm abs.
1	370-Z-120	370-Z-121	370-Z-122	370-Z-123
2	370-Z-220	370-Z-221	370-Z-222	370-Z-223
3	370-Z-320	370-Z-321	370-Z-322	370-Z-323
Disposable High Collapse (3000 psid)				
	3 μm absolute		15 μm absolute	
1	350-Z-1FFH		350-Z-110H	
2	350-Z-2FFH		350-Z-210H	
3	350-Z-3FFH		350-Z-310H	
Cleanable High Collapse (3000 psid)				
	6 μm absolute		20 μm absolute	
1	340-Z-101		340-Z-110	
2	340-Z-201		340-Z-210	
3	340-Z-301		340-Z-310	
Cleanable Mesh				
	40 μm absolute		75 μm absolute	
1	390-Z-140		390-Z-175	
2	390-Z-240		390-Z-275	
3	390-Z-340		390-Z-375	

*Included in Seal Kit: 936060 Nitrile
936061 EPR
936062 Fluorocarbon

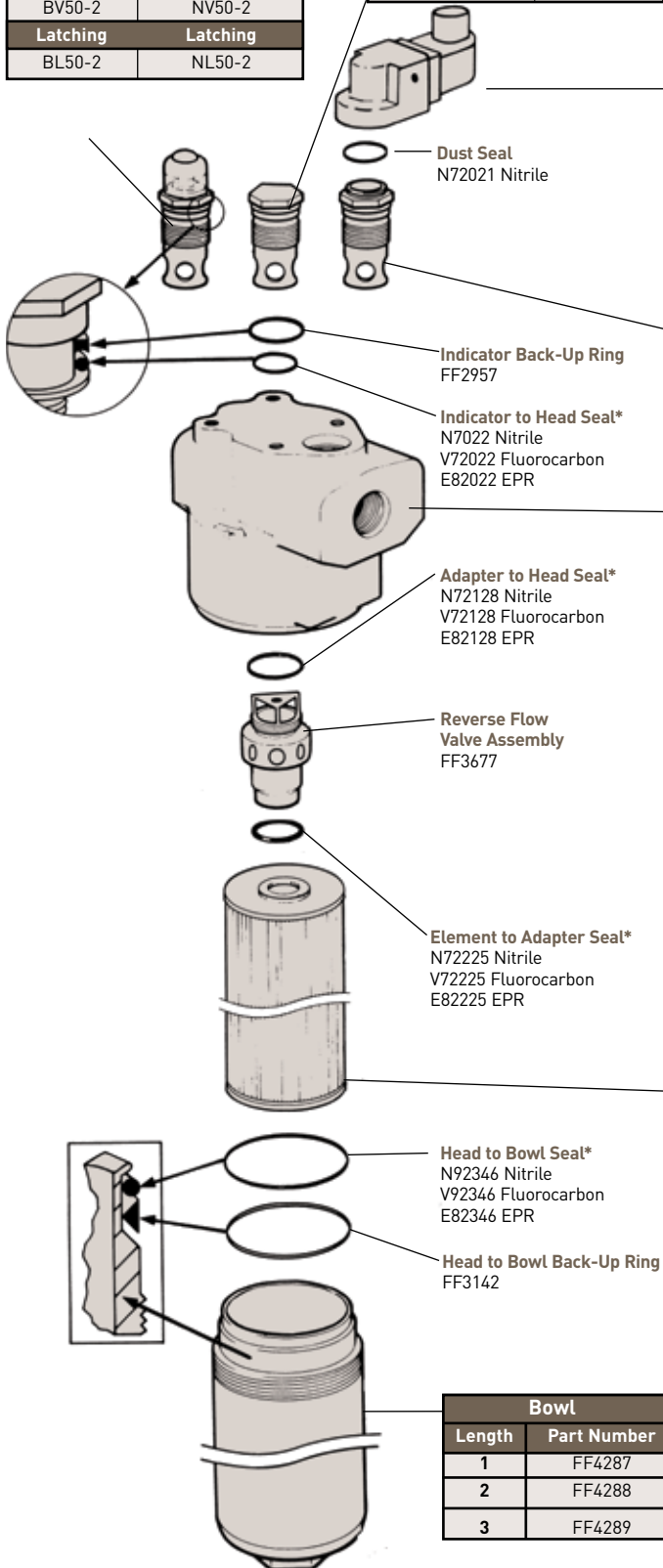

Bowl	
Length	Part Number
1	FF4287
2	FF4288
3	FF4289

Reverse Flow Pressure Filters

272/372 Series

HOW TO ORDER 372 Series Filters:

Select the desired symbol (in the correct position) to construct a model code.

Example:

STD	BOX 1	BOX 2	BOX 3	BOX 4	BOX 5	BOX 6	BOX 7	BOX 8
3	7	2	A	BV50	S	Z	1	23

Element Example:

STD	BOX 1	STD	BOX 6	BOX 7	BOX 8	BOX 3
3	7	0	Z	1	23	A

BOX 1: FILTER/ELEMENT TYPE	
Symbol	Description
7	Microglass Inorganic disposable
5	High Strength Disposable

BOX 2: FILTER FLOW	
Symbol	Description
2	With Reverse Flow Valve

BOX 3: SEALS	
Symbol	Description
A	Nitrile
H	Fluorocarbon

BOX 4: INDICATOR		
Indicator Type	BYPASS	NO BYPASS
	INDICATION @ 73 PSID [5.0 BAR]	INDICATION @ 73 PSID [5.0 BAR]
VISUAL	BV50	NV50
VISUAL-LATCHING	BL50	-
ELECTRICAL (T) 28 VDC, 110-250 VAC	BE50	NE50

BOX 5: PORT OPTIONS	
Symbol	Description
S	SAE-20 (1-5/8"-12 Thread)
F	S.A.E. 6000PSI 1-1/4" Flange
T	S.A.E. 3000PSI 1-1/2" Flange
V	Manifold Adapter

Dual Indicator Codes:

- BEE50** - Bypass with double electrical indicators
- NEE50** - No bypass with double electrical indicators
- BEV50** - Bypass with (1) mechanical visual (50 psid) and (1) electrical indicator (73 psid)
- NEV50** - No bypass with (1) mechanical visual (50 psid) and (1) electrical indicator (73 psid)

Note: Dual Indicators are not available with Port Option "V"

BOX 6: ELEMENT TYPE		
Symbol	Element Types	Absolute Ratings Micron
Z	All fluids	All ratings

BOX 7: ELEMENT LENGTH		
Symbol	Description	Type
1	Length 1	4, 5, 7, 9
2	Length 2	4, 5, 7, 9
3	Length 3	4, 5, 7, 9

BOX 8: DEGREE OF FILTRATION		
Symbol	Absolute Rating	Type
FF	3μ	5
10	15μ	5
20	3μ	7
21	6μ	7
22	10μ	7
23	20μ	7

Notes
