



Medium Pressure Filters

45M/45M Eco Series

MAX 260 l/min - 40 bar



Medium Pressure Filters

45M/45M Eco Series

Features & Benefits

Features	Advantages	Benefits
Cast iron head, steel bowl	Can be used in applications where aluminium is not allowed	Approved for engine rooms and mines
	Rugged construction	Reliable filtration in all conditions
Reinforced Microglass III replacement elements	Multi-layered design produced high capacity and efficiency	Great performance value
	Wire support reduces pleat bunching, keeps performance consistent	Reliable performance throughout element life
Visual, electrical or electronic indicators available	Check element condition at glance	Reduces downtime, maximises element life
	Right style for the application	Optimise element life, prevent bypassing
Test points in the filter head	Pressure measurement and Δp possible	Matches your system electrical connections
Coreless Ecoglass III replacement elements	No metal content in element	Quick testing and maintenance
	Reduced overall weight of 50%	Environmentally friendly disposal by incineration
	Easy compaction of used elements	Lower element replacement costs
	Eco adaptors available	Lower disposal costs
		Retrofit coreless design to housings already installed

Typical Applications

- Industrial power units
- Mobile construction equipment
- Forestry equipment

The Parker Filtration 45M/45 Eco Series Medium Pressure Filters.

The 45M/45 Eco Series of medium pressure filters offer an ideal solution to the problem of protecting system components at lower pressures.

These filters are a realistic, high quality alternative to low specification spin-on filters. The 45M/45 Eco Series offers high dirt holding capacity, 40 bar capability and rapid element replacement.



Specification

Pressure ratings:

Maximum allowable operating pressure 40 bar.
Filter housing pressure pulse fatigue tested: 10⁶ pulses 0-40 bar.

Connections:

Threads G1, G1¹/₄ (ISO 228/1) or flange SAE 1¹/₂" 3000-M.

Filter housing:

Head material cast iron (GSI).
Bowl material steel.

Seal material:

Nitrile or Fluoroelastomer.

Operating temperature range:

-20° to +100°C

Bypass valve:

Opening pressure 3.5 bar.

Filter element:

Degree of filtration:

Determined by Multipass-test according to ISO 16889.

Flow fatigue characteristics:

Filter media is supported so that the optimal fatigue life is achieved (ISO 3724).

Microglass III:

Supported with epoxy coated metal wire mesh, end cap material reinforced composite and metal inner core.
Collapse rating 20 bar (ISO 2941).

Ecoglass III:

Supported with plastic net, end cap material reinforced composite. No metal parts. Collapse rating 10 bar (ISO 2941).
Filter element can only be used together with reusable FEA Eco-adaptor.
Note: Ecoglass III contributes to ISO 14001 quality.

Indicator options:

Indicating differential pressure: 2.5 ± 0.3 bar.

- visual M3.
- electrical T1.
- electronic F1(PNP).
- electronic F2(NPN).

For indicator details see catalogue section 6.

Fluid compatibility:

Suitable for use with mineral and vegetable oils, and some synthetic oils. For other fluids, please consult Parker Filtration.

Installation Details

Type	A	B	C	Weight (kg)	D
Length 1	116 (4.57)	237 (9.33)	192 (7.56)	5.9	G1, G1 ¹ / ₄ , G1 ¹ / ₂ , Flange SAE 1 ¹ / ₂ " 3000-M
Length 2	208 (8.20)	330 (13.00)	285 (11.22)	6.2	
Length 3	329 (13.00)	450 (17.72)	405 (15.94)	6.6	
Length 4	428 (16.85)	550 (21.65)	505 (19.90)	7.0	

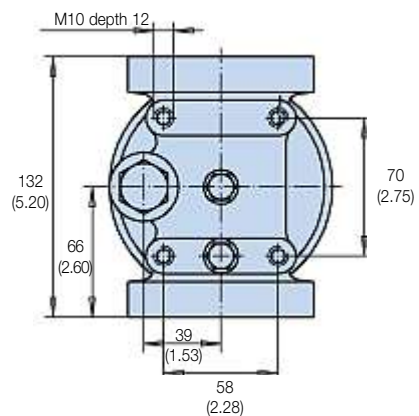
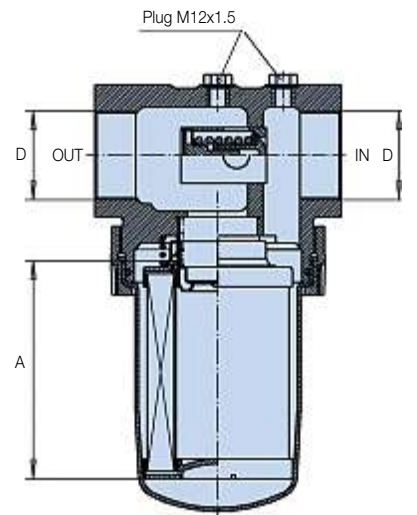
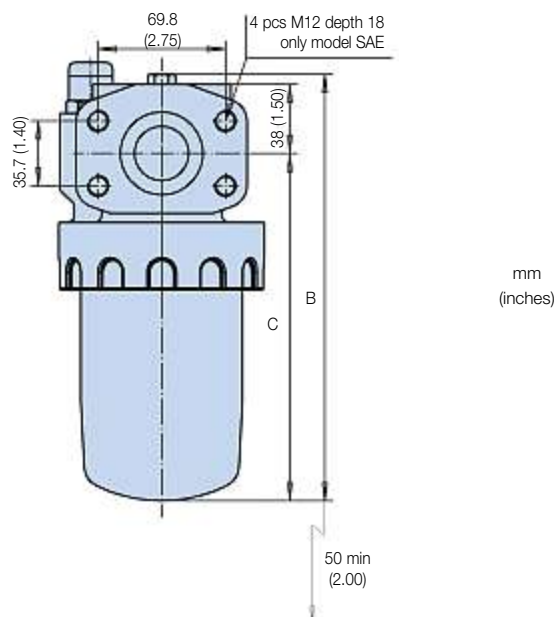

45M/45M Eco Series

Pressure Drop Curves

The recommended level of the initial pressure drop is max 1.0 bar.

If the medium used has a viscosity different from 30 cSt, pressure drop over the filter can be estimated as follows:

The total $\Delta p = \text{housing } \Delta p_h + (\text{element } \Delta p_e \times \text{working viscosity}/30)$.

45M Series Empty Housing

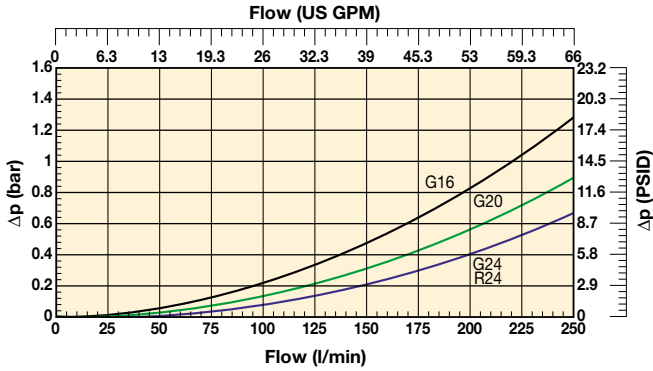

45M-1 Element with Microglass III

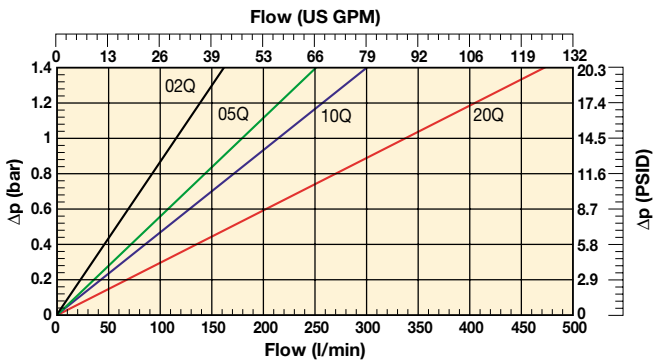

45M-2 Element with Microglass III

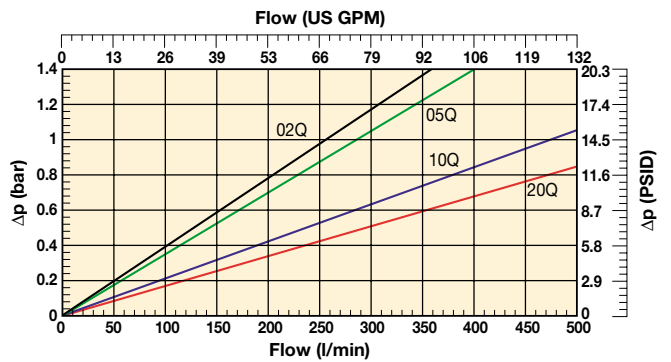

45M-3 Element with Microglass III

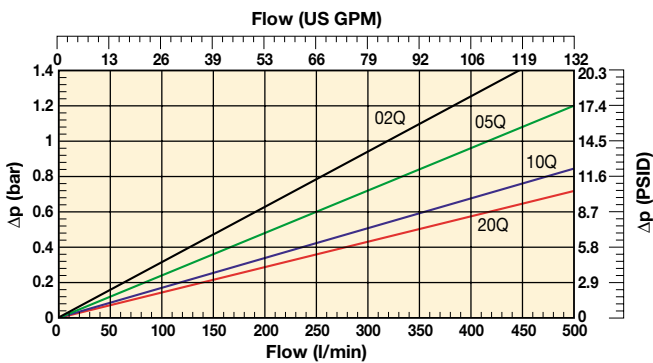

45M-4 Element with Microglass III

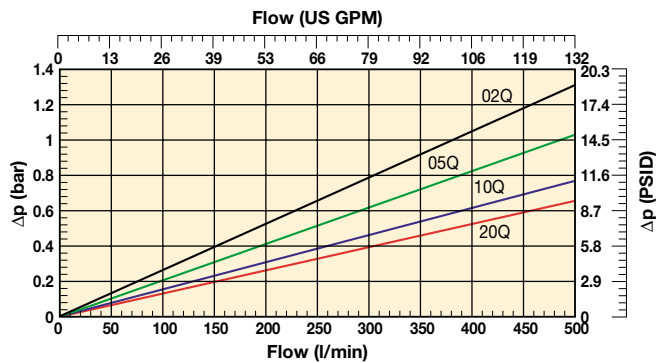

45M-1 Element with Ecoglass III

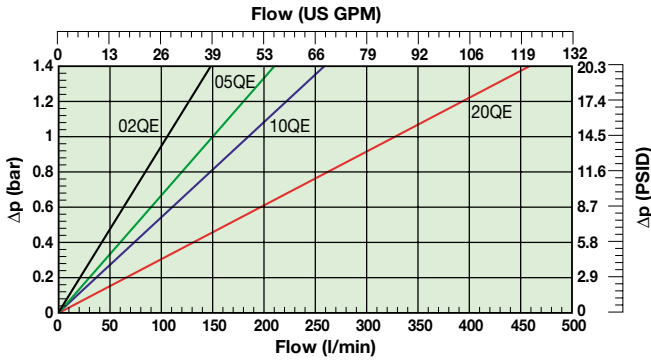

45M-2 Element with Ecoglass III

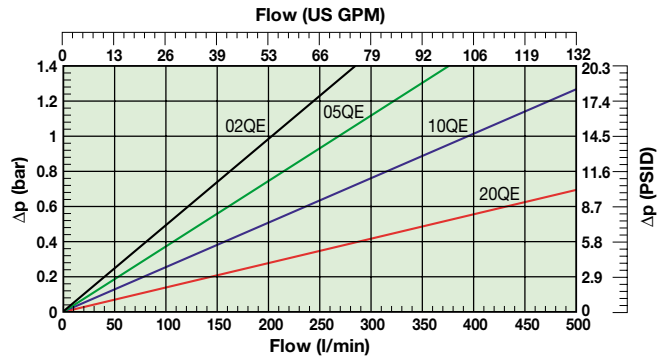

45M-3 Element with Ecoglass III

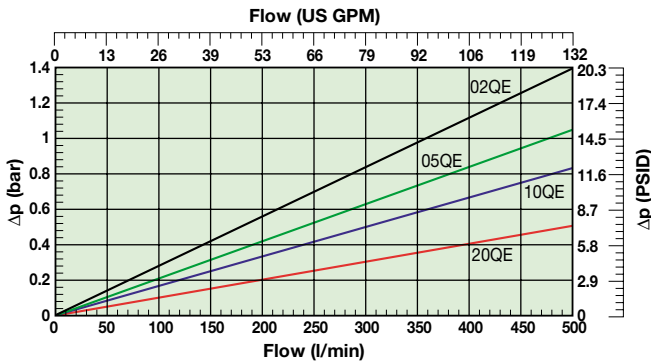

45M-4 Elements with Ecoglass III

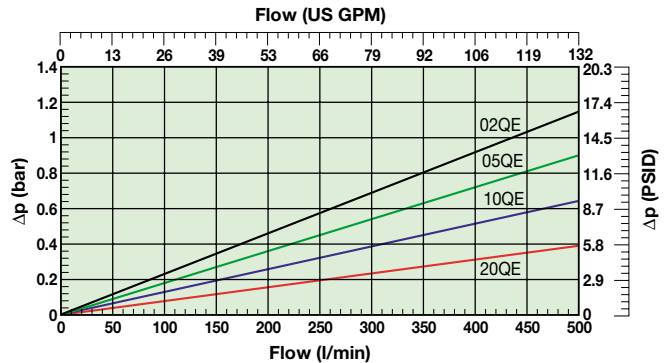

Ordering Information

Standard products table

Product numbers	Supersedes	Flow (l/min)	Model number	Element length	Media rating (μ)	Seals	Indicator	Bypass settings	Ports	Replacement elements	Supersedes
45M110QBPKG161	FF1145.Q010.BS35.GT16	140	45M	Length 1	10	Nitrile	Plugged	3.5 bar	G1"	938962Q	FC7005.Q010.BK
45M120QBPKG161	FF1145.Q020.BS35.GT16	160	45M	Length 1	20	Nitrile	Plugged	3.5 bar	G1"	938963Q	FC7005.Q020.BK
45M110QEBPKG161	FF1145.QE10.BS35.GT16	140	45M	Length 1	10	Nitrile	Plugged	3.5 bar	G1"	938978Q	FC7005.QE10.BK
45M120QEBPKG161	FF1145.QE20.BS35.GT16	160	45M	Length 1	20	Nitrile	Plugged	3.5 bar	G1"	938979Q	FC7005.QE20.BK
45M210QBPKG201	FF1146.Q010.BS35.GT20	200	45M	Length 2	10	Nitrile	Plugged	3.5 bar	G1½"	938966Q	FC7006.Q010.BK
45M220QBPKG201	FF1146.Q020.BS35.GT20	220	45M	Length 2	20	Nitrile	Plugged	3.5 bar	G1½"	938967Q	FC7006.Q020.BK
45M210QEBPKG201	FF1146.QE10.BS35.GT20	200	45M	Length 2	10	Nitrile	Plugged	3.5 bar	G1½"	938982Q	FC7006.QE10.BK
45M220QEBPKG201	FF1146.QE20.BS35.GT20	220	45M	Length 2	20	Nitrile	Plugged	3.5 bar	G1½"	938983Q	FC7006.QE20.BK
45M310QBPKG241	FF1147.Q010.BS35.GT24	230	45M	Length 3	10	Nitrile	Plugged	3.5 bar	G1½"	938970Q	FC7007.Q010.BK
45M320QBPKG241	FF1147.Q020.BS35.GT24	250	45M	Length 3	20	Nitrile	Plugged	3.5 bar	G1½"	938971Q	FC7007.Q020.BK
45M310QEBPKG241	FF1147.QE10.BS35.GT24	230	45M	Length 3	10	Nitrile	Plugged	3.5 bar	G1½"	938986Q	FC7007.QE10.BK
45M320QEBPKG241	FF1147.QE20.BS35.GT24	250	45M	Length 3	20	Nitrile	Plugged	3.5 bar	G1½"	938987Q	FC7007.QE20.BK

Note: Filter assemblies ordered from the product configurator below are on extended lead times. Where possible, please make your selection from the table above.

Note 1: Part numbers featured with bold highlighted codes will ensure a 'standard' product selection.

Medium Pressure Filters

45M/45M Eco Series

Ordering Information (cont.)

Product configurator

Box 1	Box 2	Box 3	Box 4	Box 5	Box 6	Box 7	Box 8
45M	2	10Q	B	M3	K	G20	1

Box 1

Code	
Model	Code
Medium pressure filter, T-port	45M

Highlights Key (Denotes part number availability)

123	Item is standard
123	Item is standard green option
123	Item is semi standard
123	Item is non standard

Note: Standard items are in stock, semi standard items are available within four weeks

Box 2

Filter type	
Length	Code
Length 1	1
Length 2	2
Length 3	3
Length 4	4

Box 3

Degree of filtration				
Element media	Glass fibre			
	Media code			
Microglass III element	02Q	05Q	10Q	20Q
Ecoglass III element	02QE	05QE	10QE	20QE

Note: When using Ecoglass III elements a bowl with reusable Eco-adaptor is required.

Box 4

Seal type	
Seal material	Code
Nitrile	B
Fluoroelastomer	V

Box 5

Indicator	
	Code
Plugged with steel plug	P
Visual indicator	M3
Electrical indicator	T1
Electronic 4 LED, PNP, N.O.	F1
Electronic 4 LED, NPN, N.O.	F2
Electronic 4 LED, PNP, N.C.	F3
Electronic 4 LED, NPN, N.C.	F4

Box 6

Bypass valve		
Bypass valve	Indicator	Code
3.5 bar	2.5 bar	K
No bypass*	7.0 bar	N
No bypass*	No indicator (P)	X

+ Box 8: code 2
+ Box 8: code 2

* High collapse element must be used if MAOP is higher than element collapse pressure.
When filter includes a bypass valve but not an indicator, code denotes bypass setting.

Box 7

Filter connection					
Connections	Code	Length 1	Length 2	Length 3	Length 4
Thread G 1	G16	S	S	S	x
Thread G 1 1/4	G20	S	S	S	S
Thread G 1 1/2	G24	x	S	S	S
SAE flange 1 1/2" 3000-M	R24	x	x	x	x

Availability: **S** = standard option
x = non-standard, ask for availability

Box 8

Options	
Options	Code
Standard	1
No bypass	2

Replacement elements with nitrile seals				
Media	Length 1	Length 2	Length 3	Length 4
02Q	938960Q	938964Q	938968Q	938972Q
05Q	938961Q	938965Q	938969Q	938973Q
10Q	938962Q	938966Q	938970Q	938974Q
20Q	938963Q	938967Q	938971Q	938975Q
02QE	938976Q	938980Q	938984Q	938988Q
05QE	938977Q	938981Q	938985Q	938989Q
10QE	938978Q	938982Q	938986Q	938990Q
20QE	938979Q	938983Q	938987Q	938991Q

Nominal flow (l/min) at viscosity 30 cSt - connection size				
Filter length	Media	G16	G20	G24 & R24
Length 1	02Q/02QE	80	80	80
	05Q/05QE	120	120	120
	10Q/10QE	140	150	150
	20Q/20QE	160	180	200
Length 2	02Q/02QE	130	150	170
	05Q/05QE	150	170	190
	10Q/10QE	170	200	230
	20Q/20QE	190	220	250
Length 3	02Q/02QE	150	170	190
	05Q/05QE	170	190	210
	10Q/10QE	190	210	230
	20Q/20QE	200	230	250
Length 4	02Q/02QE	170	190	210
	05Q/05QE	180	210	230
	10Q/10QE	190	220	240
	20Q/20QE	200	230	260

Degree of filtration						Code	
Average filtration beta ratio β (ISO 16889) / particle size μm [c]							
$\beta_x(c)=2$	$\beta_x(c)=10$	$\beta_x(c)=75$	$\beta_x(c)=100$	$\beta_x(c)=200$	$\beta_x(c)=1000$		
% efficiency, based on the above beta ratio (β_x)							
50.0%	90.0%	98.7%	99.0%	99.5%	99.9%	Disposable Microglass III	Metal free Ecoglass III
N/A	N/A	N/A	N/A	N/A	4.5	02Q	02QE
N/A	N/A	4.5	5	6	7	05Q	05QE
N/A	6	8.5	9	10	12	10Q	10QE
6	11	17	18	20	22	20Q	20QE