



KLT and KLS Series

Tank Top Return Line Filters



Tank Top Return Line Filters

KLT and KLS Series

Applications for KLT and KLS Filters

- Mobile Equipment
- Construction, Refuse
- Industrial Power Units
- Machine Tool
- Oil Field

Parker's new KLS /KLT Tank Top Return Line Filters are ideally suited for Mobile and Industrial high to medium flow return applications, from 30 to 120 GPM. This cost-effective, in-tank filter series provides maximum flow and dirt holding capacity for longer filter element life in a simple, easy-to-install-and-service assembly.

The generous element size with extensive media area ensures continuous filtration during cold start up conditions. The inside-to-out flow path with closed bottom provides additional assurance that all contaminants remain captured during element service removal.

The filters have a pressure rating of 150 psi static and a temperature range of -40°F to 225°F and are available in a wide range of high-efficiency Microglass III media in 2, 5, 10 and 20 micron for all system cleanliness requirements. Bypass valves are built into the element to ensure further performance integrity. A new bypass is provided with each element change.

This rugged design meets the needs for the demanding applications in mobile off-highway and on-highway applications for construction equipment, logging, refuse vehicles, mining, oil and gas recovery, marine, and industrial power units.



Feature	Advantage	Benefit
<ul style="list-style-type: none"> • Tank top mounted filter 	<ul style="list-style-type: none"> • Saves space and reduces mounting hardware 	<ul style="list-style-type: none"> • Lower cost, easy to integrate • KLS model directly retrofits competitive housing
<ul style="list-style-type: none"> • Two-piece head and element construction perforated with metal outer wrap 	<ul style="list-style-type: none"> • No bowl required • Provides excellent flow diffusing, eliminating aeration 	<ul style="list-style-type: none"> • Reduced cost and assembly weight • Improves performance
<ul style="list-style-type: none"> • High efficiency Microglass III media maximizing filtration area 	<ul style="list-style-type: none"> • Combines high particle capture efficiency with high dirt holding capacity and lower ΔP 	<ul style="list-style-type: none"> • Cleaner fluids, longer lasting with fewer service intervals • Continuous filtration for cold start ups • Lower operating costs
<ul style="list-style-type: none"> • Element design includes integral disposable bypass valve with closed bottom end cap 	<ul style="list-style-type: none"> • New bypass with each element change • Ensures captured contaminants are removed with each element change 	<ul style="list-style-type: none"> • Ensures reliable bypass performance • No leakage • Cleaner fluids reduce risk for contamination during service
<ul style="list-style-type: none"> • Magnetic prefiltration 	<ul style="list-style-type: none"> • Removes large ferrous contaminants 	<ul style="list-style-type: none"> • Extends element life • Visual indication of component wear
<ul style="list-style-type: none"> • Fill and gauge ports 	<ul style="list-style-type: none"> • Add fluid through high performance filter media • Gauge ports allow for added instrumentation 	<ul style="list-style-type: none"> • Initial fluid integrity extends system component life • Monitor element life

Tank Top Return Line Filters

KLT and KLS Series

Specifications: KLT/KLS

Pressure Ratings:

Maximum Allowable Operating Pressure (MAOP): 150 psi (10.3 bar)

Operating Temperatures:

-40°F (-40°C) to 225°F (107°C)

Element Burst Rating:

150 psid (10.3 bar)

Filtration Rating:

2, 5, 10 & 20 Microns at Beta \geq 200

Element Condition Indicators:

Gauge: 0-60 psi color coded

Switch: SPDT 5A @ 24 VDC and 250 VAC

Materials:

Head & Cover: Cast Aluminum Alloy

Bypass Valve: Nylon

Filter Media: Microglass III

Element End Caps: Nylon

Weights (approximate):

KLT-2 3 lbs. (1.36 kg)

KLT-4 4 lbs. (1.81 kg)

KLT(S)-7 8 lbs. (3.63 kg)

KLT(S)-8 10 lbs. (4.54 kg)

KLT Weld Plate Drawings

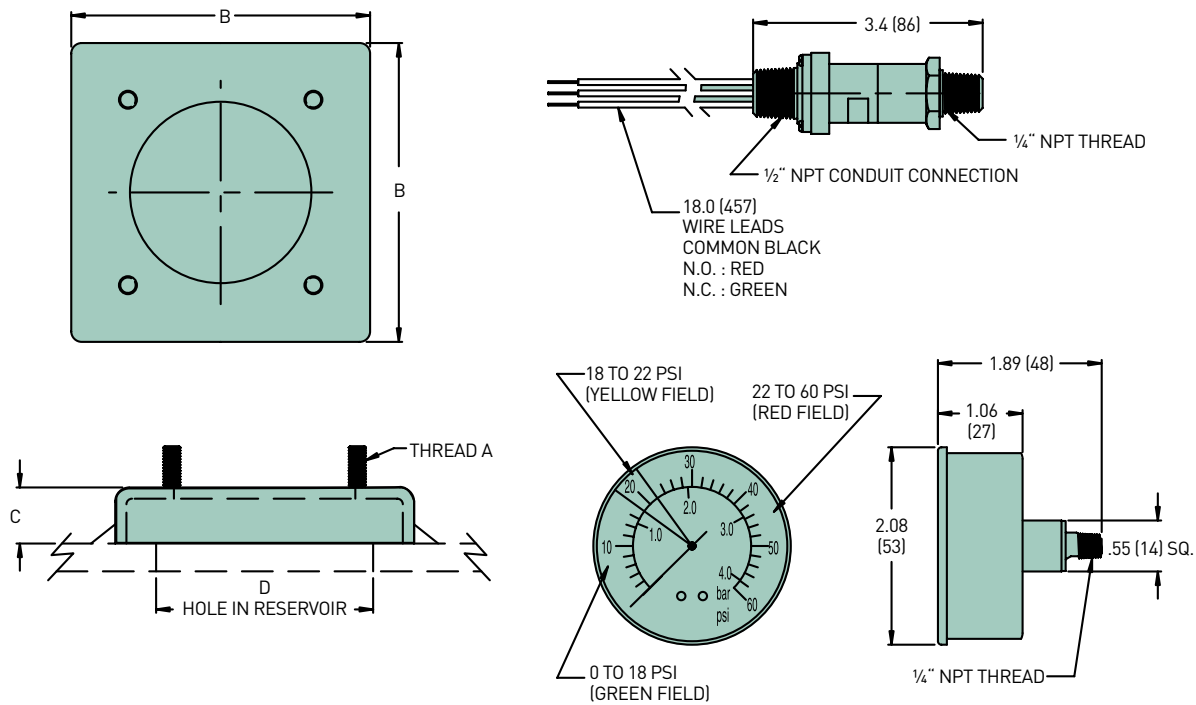

Linear Measure: inch (mm)

Dimensions	KLT Filter Model	
	KLT-2/KLT-4	KLT-7/KLT-8
A	5/16-18 UNC-2A	3/8-16 UNC-2A
B	5.33 (135)	7.15 (182)
C	1.00 (25)	1.00 (25)
D	4.50/3.75 (114/95)	6.25/5.50 (159/140)

Tank Top Return Line Filters

KLT and KLS Series

KLT Drawings

KLT 2 / KLT 4

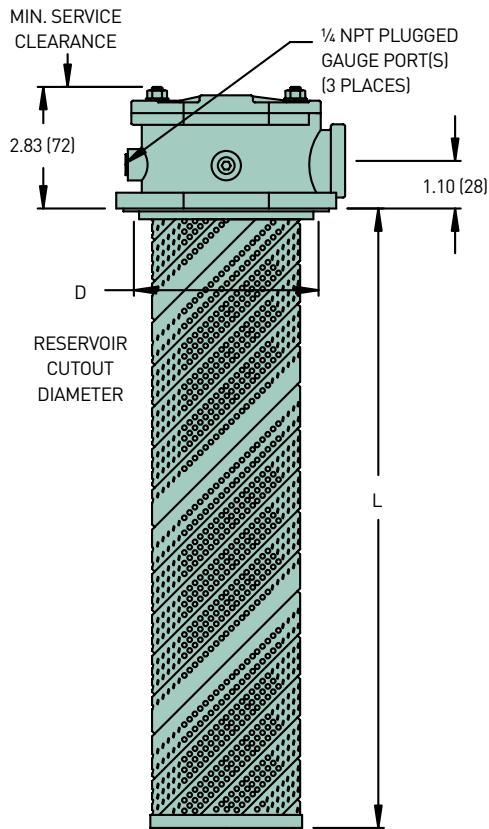
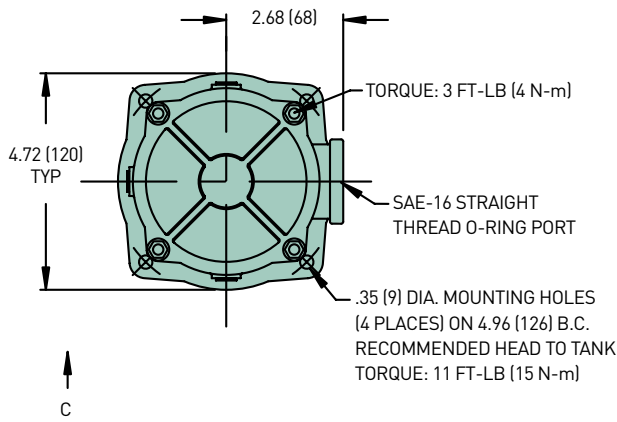

Dimensions	KLT Filter Model	
	KLT-2	KLT-4
C	5.75 (146)	9.50 (241)
L	4.16 (106)	7.75 (197)
D	3.6/3.56 (93/90)	

KLT 7 / KLT 8

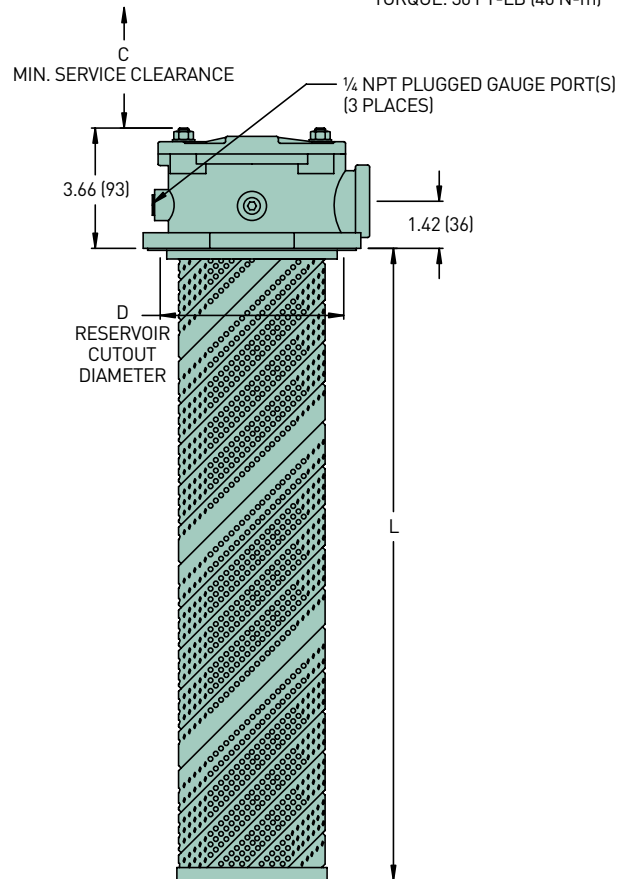
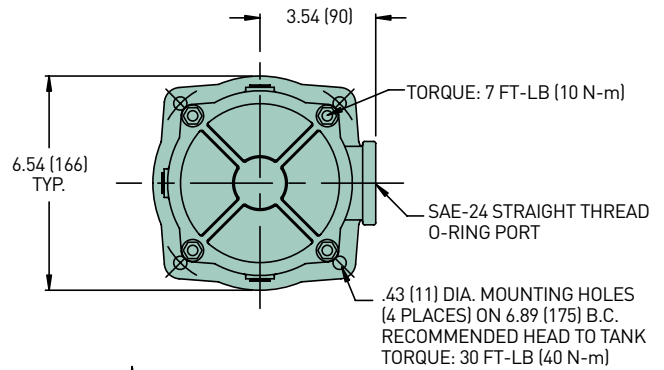

Dimensions	KLT Filter Model	
	KLT-7	KLT-8
C	13.00 (330)	19.25 (489)
L	11.46 (291)	17.70 (450)
D	5.36/5.26 (136/133)	

Linear Measure: inch (mm)

KLS Drawing

KLS 7 / KLS 8

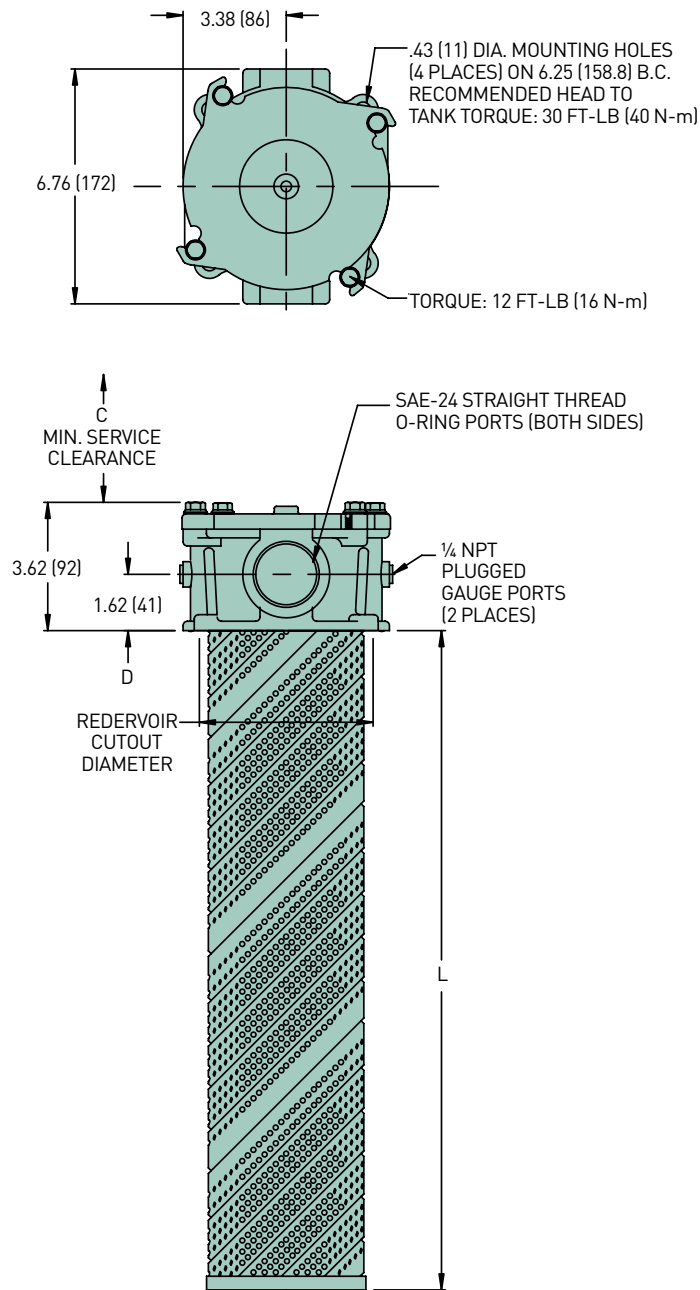

Dimensions	KLS Filter Model	
	KLS-7	KLS-8
C	13.00 (330)	19.25 (489)
L	11.46 (291)	17.70 (450)
D	5.00/4.80 (127/122)	

Linear Measure: inch (mm)

Tank Top Return Line Filters

KLT and KLS Series

KLT-2 Element Performance

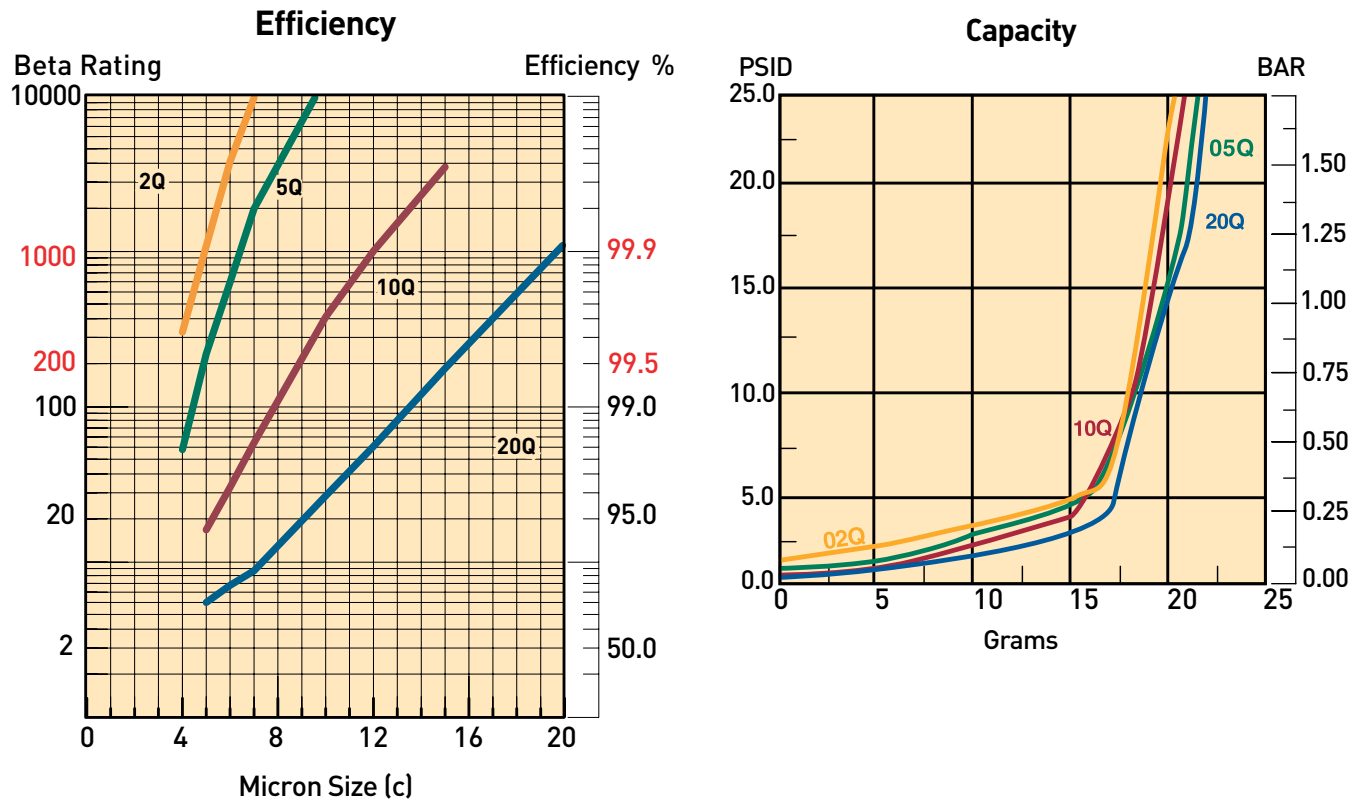

Multipass tests run @ 15 gpm to 25 psid terminal - 10 mg/L BUGL

Flow vs. Pressure Loss

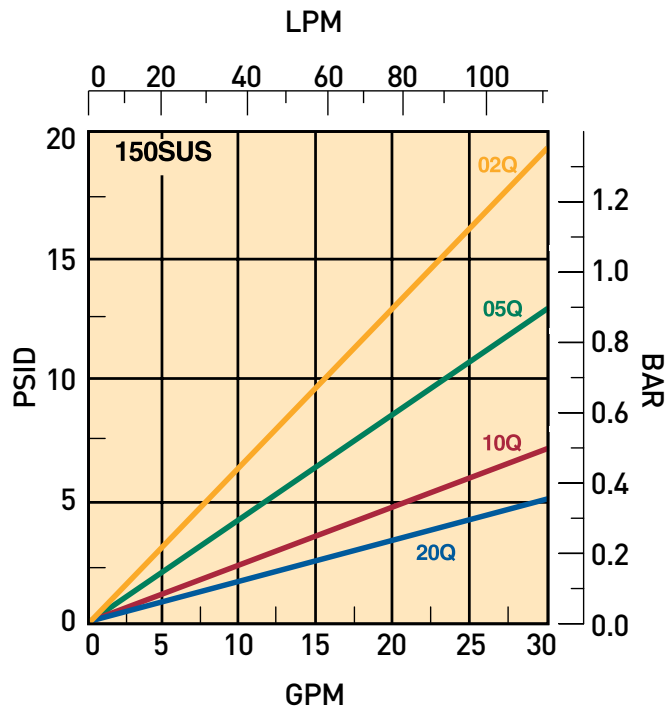

KLT-4 Element Performance

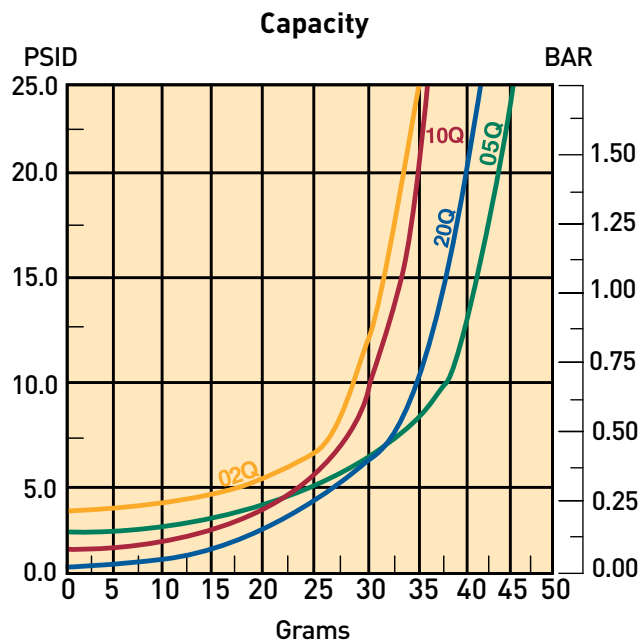
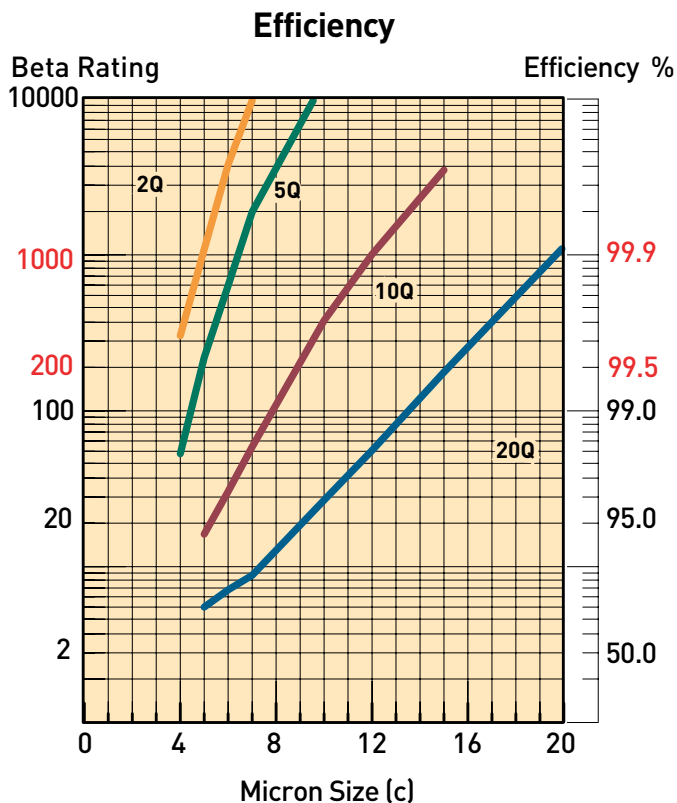

Multipass tests run @ 30 gpm to 25 psid terminal - 10 mg/L BUGL

Flow vs. Pressure Loss

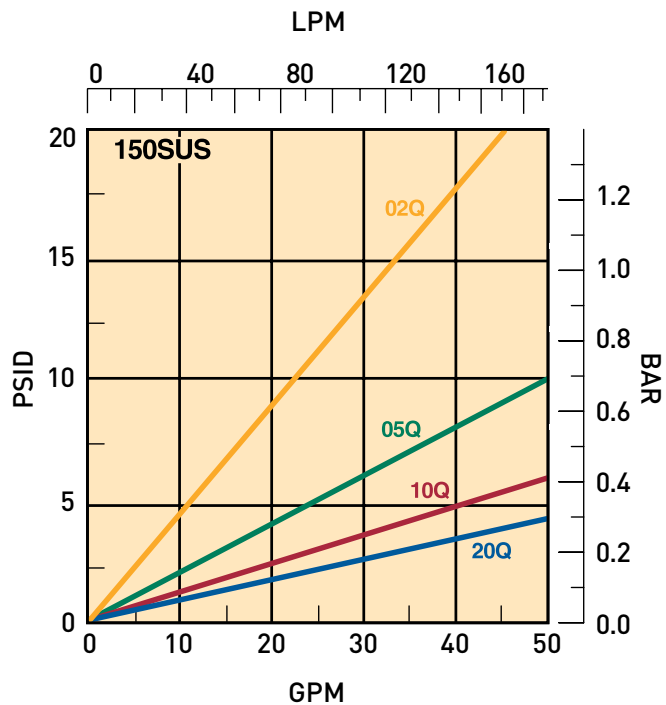

Tank Top Return Line Filters

KLT and KLS Series

KLT/S-7 Element Performance

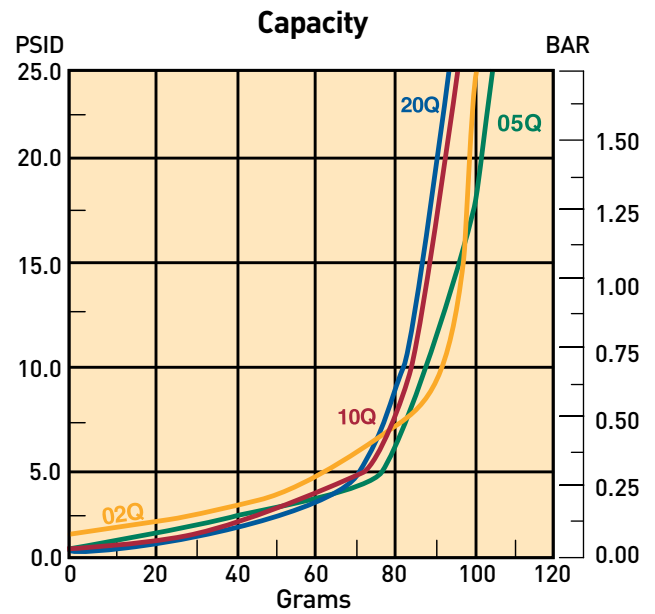
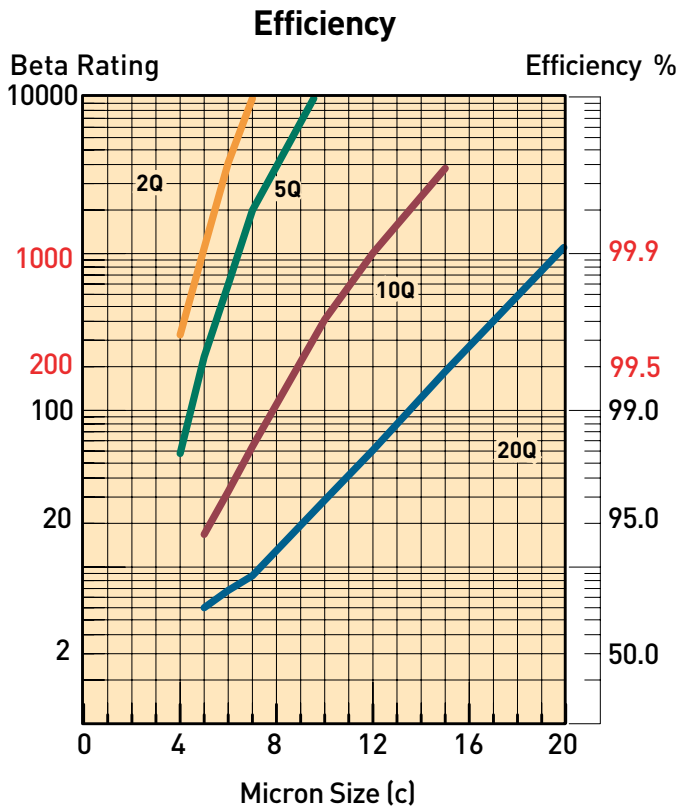

Multipass tests run @ 50 gpm to 25 psid terminal - 10 mg/L BUGL

Flow vs. Pressure Loss

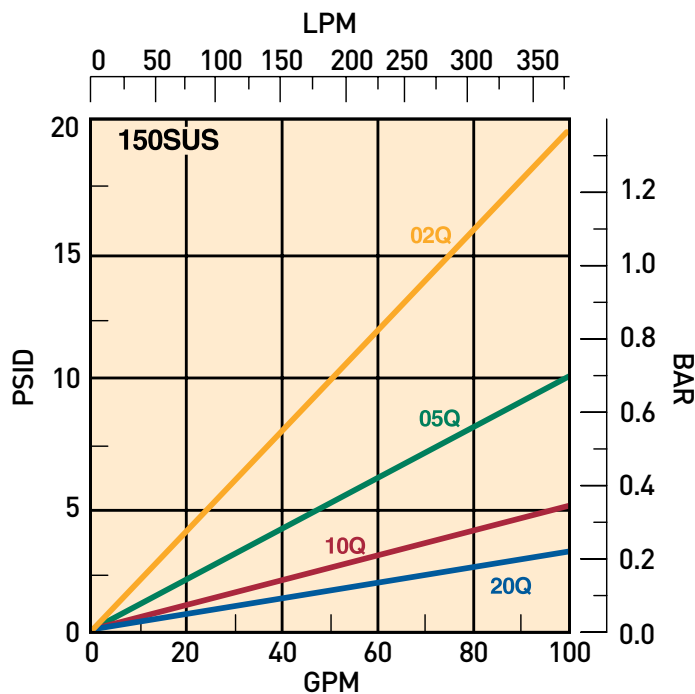

KLT/S-8 Element Performance

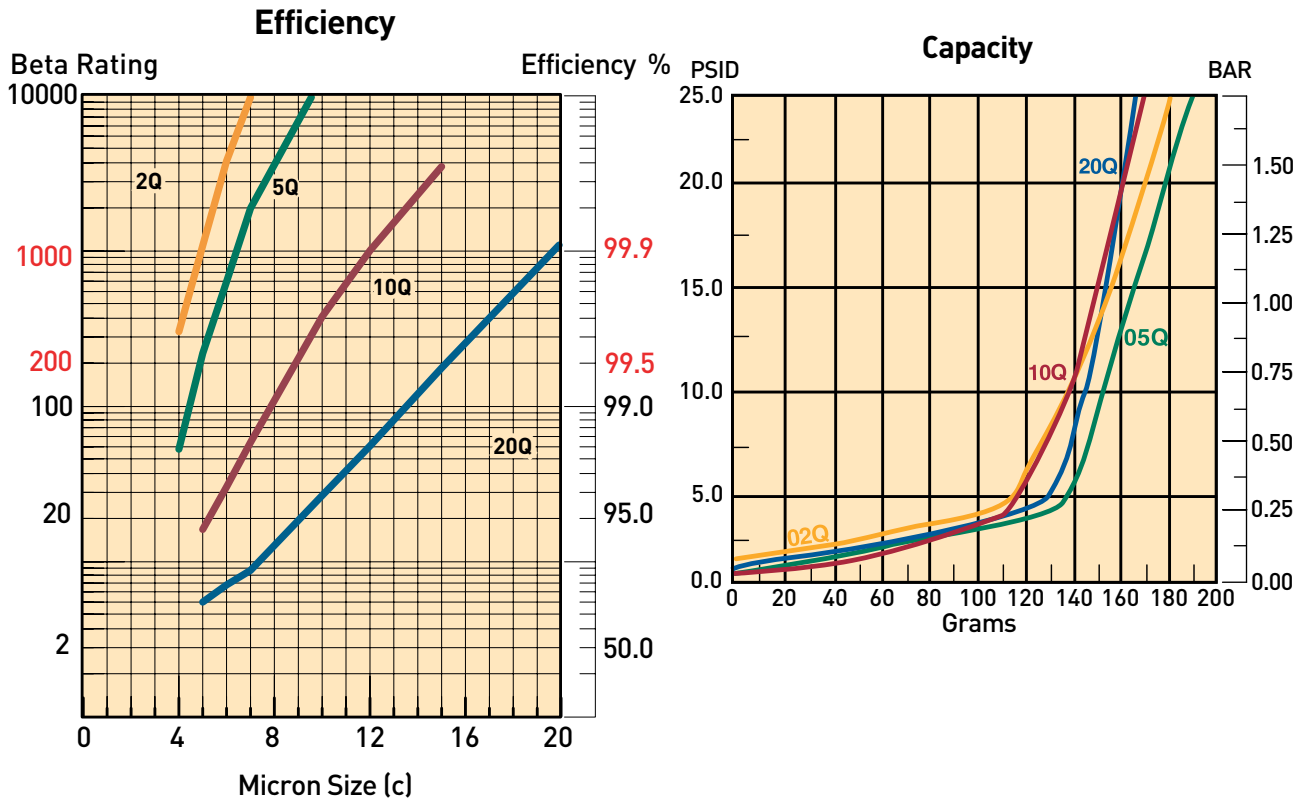

Multipass tests run @ 70 gpm to 25 psid terminal - 10 mg/L BUGL

Flow vs. Pressure Loss

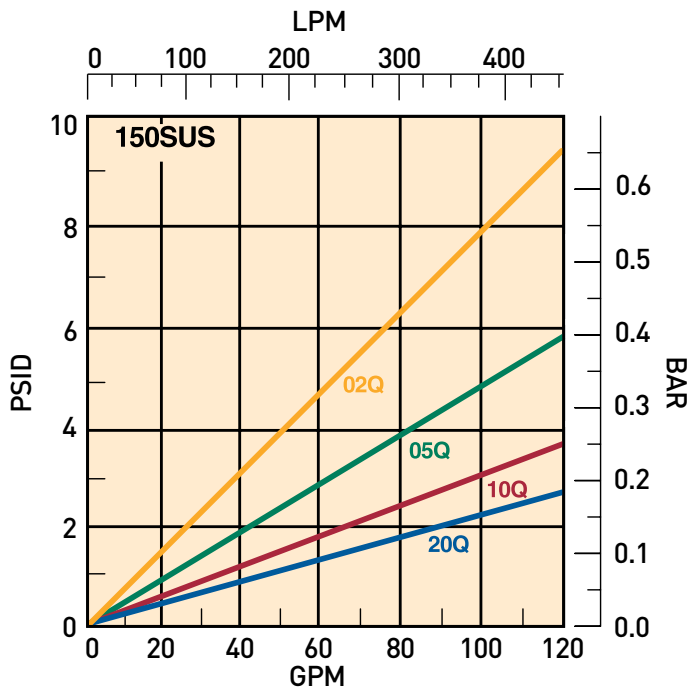

Tank Top Return Line Filters

KLT and KLS Series

Operating and Maintenance Instructions Model KLT and KLS Tank Top Filters

A. Mounting

1. Standard mounting.
 - a. Cut proper size hole in the top of the reservoir.
 - b. Drill holes for studs within the proper bolt circle.
 - c. Set the filter into the cutout hole and secure with proper size bolts, nuts and lock washers.
 - d. Torque nuts in accordance with drawing.
2. Mounting procedure using weld plate.
 - a. Rough cut proper size hole in the top of reservoir.
 - b. Weld the weld plate concentric to the rough cut hole.
 - c. Mount the filter onto the studs and secure with nuts and lock washers.
 - d. Torque nuts in accordance with drawing.
3. Utilize proper fittings.

B. Start-Up

1. Check for and eliminate leaks upon system start-up.
2. Check differential pressure indicator, if installed, to monitor element condition.

C. Service

1. An element must be serviced when the indicator indicates service is required.

NOTE: If the filter is not equipped with an indicator, the element should be serviced according to machine manufacturer's instructions.

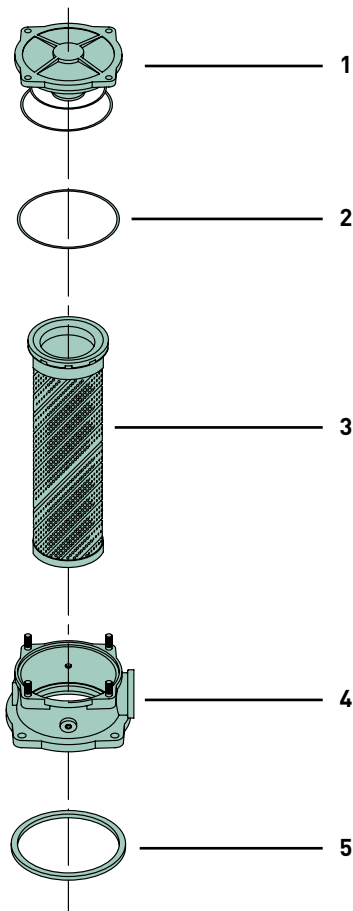

Parts List

Index	Description	Part Number	Quantity	
1	Cover Assembly (Includes Cover O-Ring)			
		KLT2/KLT4	937049	1
		KLT7/KLT8	937047	1
	KLS7/KLS8	937048	1	
2	Cover O-Ring			
		KLT2/KLT4, Nitrile	N72239	1
		KLT2/KLT4, FKM	V72239	1
		KLT7/KLT8, Nitrile	N72251	1
		KLT7/KLT8, FKM	V72251	1
		KLS7/KLS8, Nitrile	N72251	1
		KLS7/KLS8, FKM	V72251	1
3	Element (See Model Code Page)			
4	Filter Head (Includes Gauge Plugs & Studs)			
		KLT2/KLT4	5841216	1
		KLT7/KLT8	5841224	1
	KLS7/KL8	937318	1	
5	Tank Gasket			
		KLT2/KLT4	108x98x5.5B	1
		KLT7/KLT8	152x136x6B	1
	KLS7/KLS8	N72355	1	
Not Shown	Weld Plate			
		KLT2/KLT4	300041	1
		KLT7/KLT8	300042	1
	KLS7/KLS8	C.F.	1	
Not Shown	Pressure Switch	NS-1C-19R/EL	1	
Not Shown	Pressure Gauge	936913	1	

C.F. = Consult Factory

D. Servicing Dirty Element

1. Shut system down to assure that there is NO PRESSURE OR FLOW into the filter housing.
2. Remove the filter cover.
3. Remove and discard the contaminated element cartridge.

E. Before Installing a New Element Cartridge

1. Clean the magnetic core with a lint-free cloth.
2. Check all seals and replace if necessary.

G. To Install a New Element Cartridge

3. Lubricate all seals.
4. Mount new or cleaned filter cartridge.
5. Re-install the cover.
6. Torque the cover nuts per drawing.

Perform procedures B1 and B2 to ensure no leaks are present.

Tank Top Return Line Filters

KLT and KLS Series



HOW TO ORDER:

Select the desired symbol (in the correct position) to construct a model code.

Example:

BOX 1	BOX 2	BOX 3	BOX 4	BOX 5	BOX 6	BOX 7	BOX 8
KLT	7	10Q	B	P	G	S24	1

BOX 1: Filter Series	
Symbol	Description
KLT	Single Port Return-Line Filter
KLS	Dual Port Return-Line Filter (230 & 300 only)

BOX 2: Model	
Symbol	Description
2	30 GPM (115 l/m) nominal flow
4	50 GPM (190 l/m) nominal flow
7	100 GPM (380 l/m) nominal flow
8	120 GPM (455 l/m) nominal flow

BOX 3: Media Code	
Symbol	Description
02Q	Microglass III, 2 micron
05Q	Microglass III, 5 micron
10Q	Microglass III, 10micron
20Q	Microglass III, 20micron
WR	Water Removal

BOX 4: Seals	
Symbol	Description
B	Nitrile
V	Fluorocarbon

*Note: Nitrile tank gasket always supplied.

BOX 5: Indicator	
Symbol	Description
P	No indicator; plugged pressure port(s)
G	Pressure Gauge, 0-60 PSIG
S	Pressure Switch

BOX 6: Bypass	
Symbol	Description
G	25 PSI (1.7 bar) setting

BOX 7: Port	
Symbol	Description
KLT-2/4	
S16	SAE-16 (1 5/16" -12)
KLT-7/8	
S24	SAE-24 (1 7/8" -12)
KLS-7/8	
S24	2 x SAE-24 (1 7/8" -12)

BOX 8: Options	
Symbol	Description
1	None
TP	Weld Plate (KLT only)

Please note the bolded options reflect standard options with a reduced lead-time. Consult factory on all other lead-time options.

Replacement Elements

Element Code	Nitrile				Fluorocarbon			
	2	4	7	8	2	4	7	8
20Q	936967Q	936971Q	936975Q	936979Q	937269Q	937273Q	937277Q	937281Q
10Q	936966Q	936970Q	936974Q	936978Q	937268Q	937272Q	937276Q	937280Q
05Q	936965Q	936969Q	936973Q	936977Q	937267Q	937271Q	937275Q	937279Q
02Q	936964Q	936968Q	936972Q	936976Q	937266Q	937270Q	937274Q	937278Q
WR	937258	937259	937260	937261	C.F.	C.F.	C.F.	C.F.

C.F. = Consult Factory

Replacement Cover Kits

Cover Kit		
Assembly/Model	P/N	
KLT	2/4	937049
	7/8	937047
KLS	7/8	937048



Global products as identified are offered worldwide through all Parker locations and utilize a common ordering code.

Notes
