



Moduflow™ *Plus* Series

ILP and RFP Low Pressure Filters



Low Pressure Filters

Moduflow™ Plus Series

Applications for Moduflow Filters

- Power Unit Fabrication
- Off-line Filter Loops
- Mobile Equipment

The Moduflow filter is widely considered the most versatile filter available on the market. The unique diverter valve assembly, and inside to outside flow through the element, allows the Moduflow to be configured for in-line, in-tank or suction filtration.

The flow diverter minimizes turbulence and pressure loss through the filter, improving system performance.

The newly designed closed bottom elements for the RFP and ILP models insures all contamination remains trapped within the element as the filter is serviced.

A wide variety of visual and electrical indicators allows you to know exactly when the element needs to be serviced. There is even a "no element" indicator that can sense when there is not an element installed in the filter.

From top to bottom, the Moduflow filter series provides the high level of filtration and long term dependability so vital to today's hydraulic systems.



Parker's new patented Moduflow element was designed with built-in diverter cone and bypass valve, to meet your application needs.

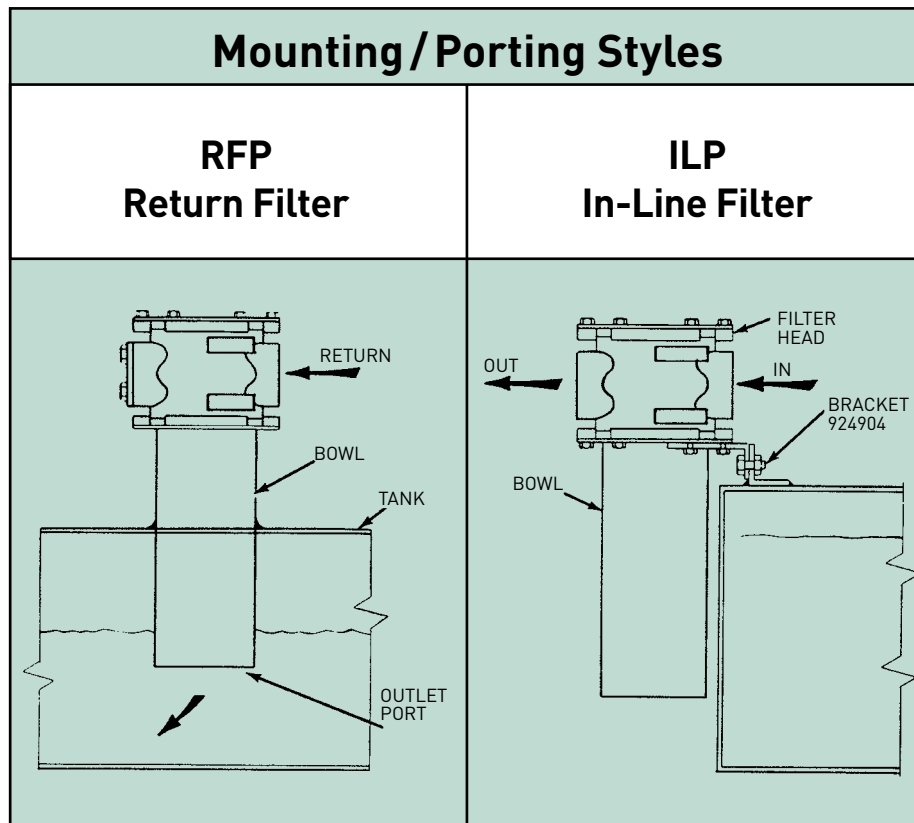

Features

Flanges

- NPT or SAE 3/4" to 2"
- Lightweight aluminum

Cover

- Slotted for quick release
- Lightweight aluminum

Indicators

- Visual or electrical
- Mounted on either side
- Standard "no element" indication

Bowl

- Single or double length
- Durable steel construction

Bypass

(not visible)

- Integral 35 psi bypass replaced with every element change

Element

(not visible)

- Available in cellulose, wire mesh or high performance Microglass III media
- Single or double length



Feature	Advantage	Benefit
<ul style="list-style-type: none"> • Top access element service 	<ul style="list-style-type: none"> • Oil remains in housing • Quicker elements change 	<ul style="list-style-type: none"> • No Spills • Reduced maintenance costs
<ul style="list-style-type: none"> • Slotted cover 	<ul style="list-style-type: none"> • Quick release cover • Cap screws remain in housing 	<ul style="list-style-type: none"> • Reduced maintenance costs • No loose parts to lose
<ul style="list-style-type: none"> • Closed bottom elements 	<ul style="list-style-type: none"> • Removes all contaminant during element service 	<ul style="list-style-type: none"> • No downtime contamination from servicing
<ul style="list-style-type: none"> • Visual or electrical indicators 	<ul style="list-style-type: none"> • Know exactly when to service elements 	<ul style="list-style-type: none"> • Helps prevent bypass condition • No premature disposal
<ul style="list-style-type: none"> • Flange face ports 	<ul style="list-style-type: none"> • Flexible mounting (3/4" to 2") 	<ul style="list-style-type: none"> • Easy plumbing to your system

Low Pressure Filters

Moduflow™ Plus Series

RFP-1 & ILP-1 Element Performance

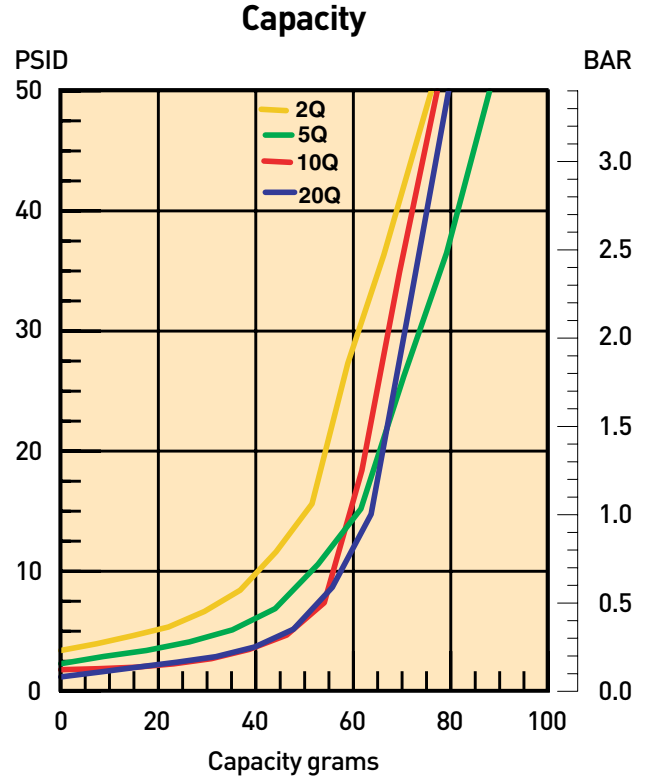
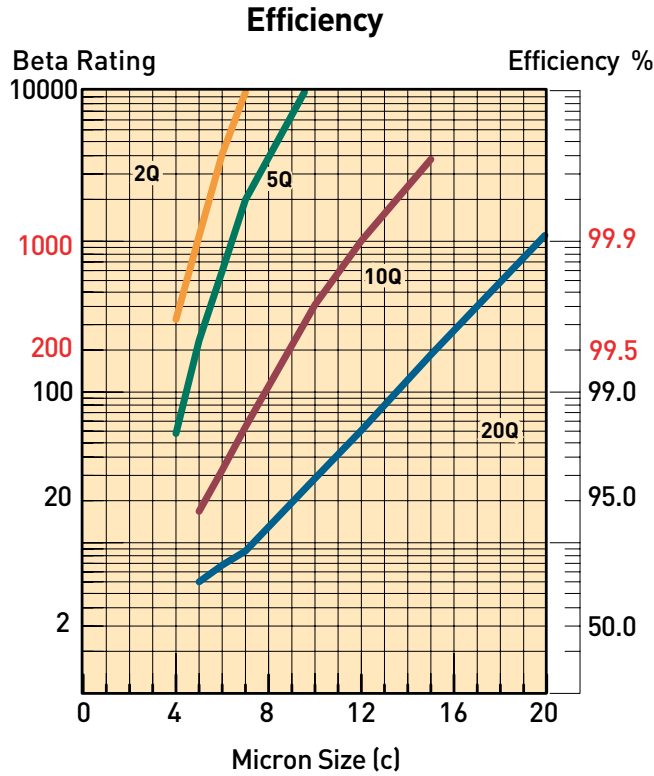

Multipass tests run @ 40 gpm to 50 psid terminal - 5mg/L BUGL

Flow vs. Pressure Loss

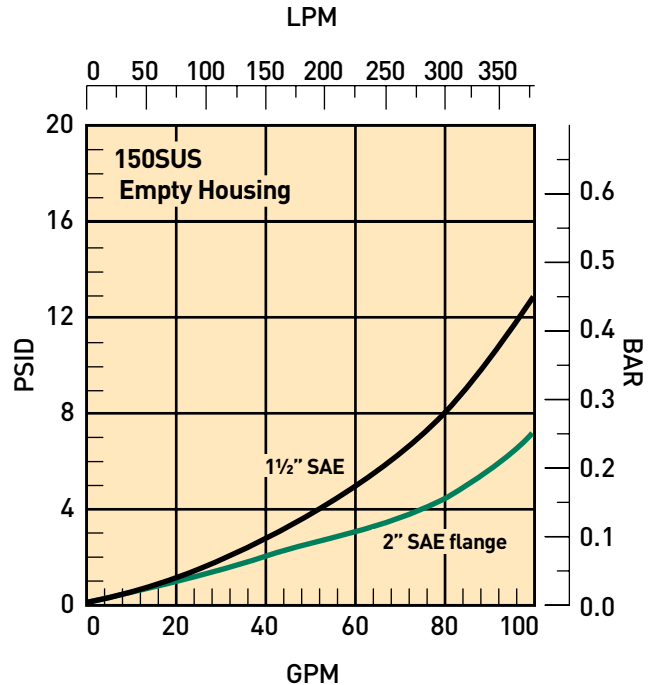
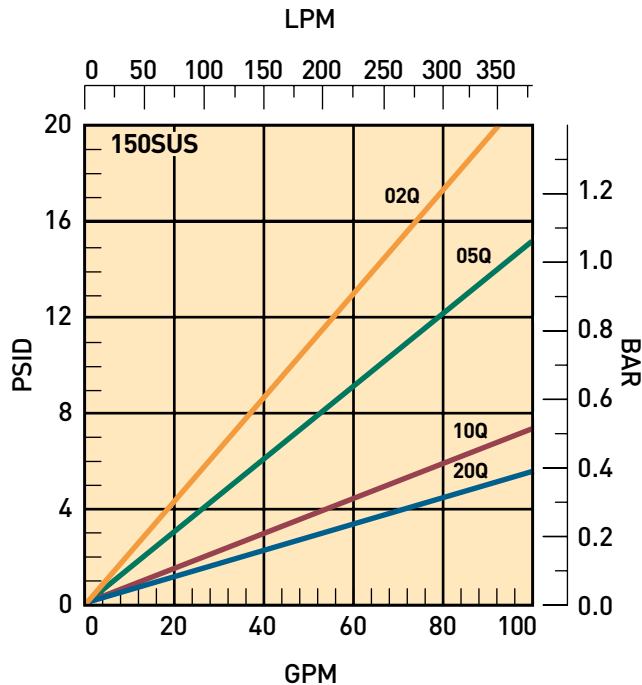

RFP-2 & ILP-2 Element Performance

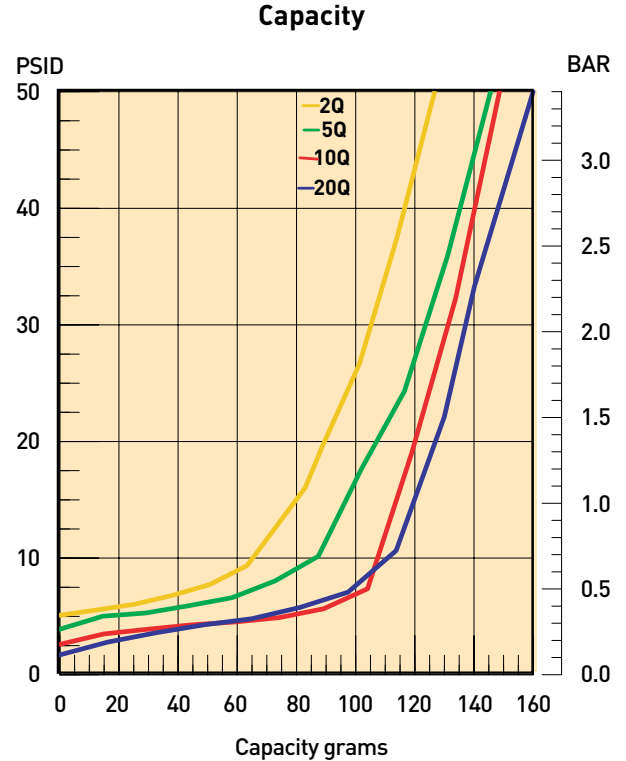
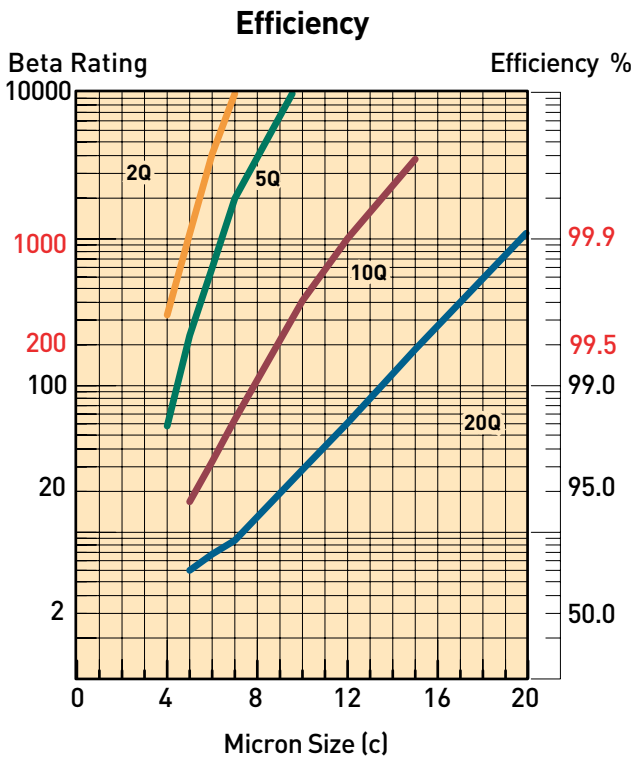

Multipass tests run @ 80 gpm to 50 psid terminal - 5mg/L BUGL

Flow vs. Pressure Loss

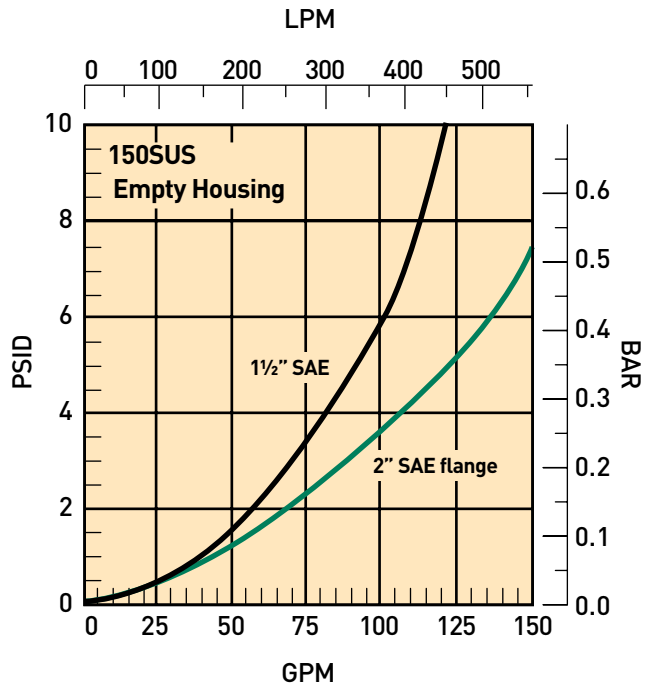
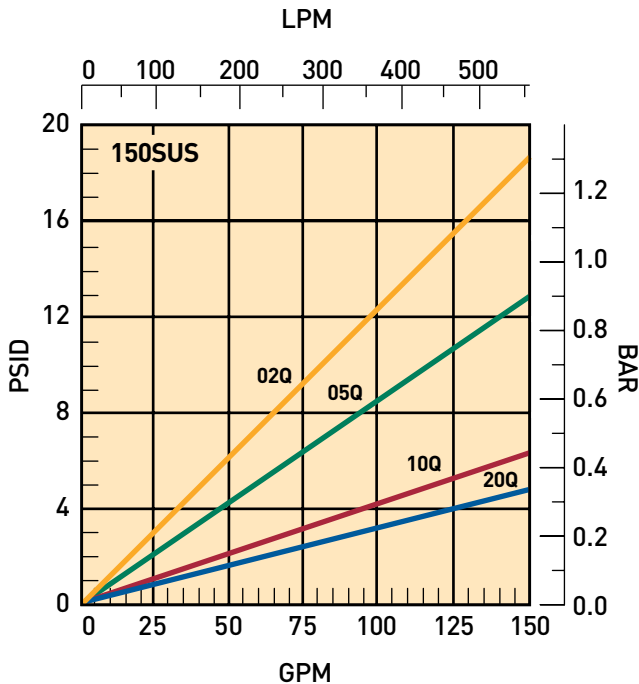

Low Pressure Filters

Moduflow™ Plus Series

Specifications: RFP, ILP

Pressure Ratings:

Maximum Allowable Operating Pressure (MAOP): 200 psi (13.8 bar)

Design Safety Factor: 2:1

Rated Fatigue Pressure: 150 psi (10.3 bar)

Element Burst Rating: 70 psid (4.8 bar)

Filter Materials:

Head, Cover, Flanges: die cast aluminum
Bowl: steel

Operating Temperatures:

Nitrile: -40°F to 225°F (-40°C to 107°C)

Fluorocarbon: -15°F to 275°F (-26°C to 135°C)

Weight (approximate):

Single: 20 lbs. (9.1 kg)

Double: 25 lbs. (11.3 kg)

Indicators:

Visual (optional)

Electrical (optional) 15A @ 250VAC / .5A @ 125 VDC

Electrical ("D" option) 5A @ 250VAC / 3A @ 28 VDC

Color Coding:

White (normally closed)

Red (normally open)

Black (common)

Dimensions: mm inch

Model	A	B	C	D
RFP-1 without optional 2" fitting	$\frac{65.0}{2.56}$	$\frac{330.2}{13.0}$	—	$\frac{110.0}{4.3}$
ILP-1	$\frac{65.0}{2.56}$	$\frac{330.2}{13.0}$	N/A	$\frac{110.0}{4.3}$
RFP-1 with optional 2" fitting	$\frac{68.3}{2.69}$	—	$\frac{383.4}{15.07}$	$\frac{114.0}{4.5}$
RFP-2	$\frac{68.3}{2.69}$	$\frac{617.5}{24.31}$	$\frac{623.8}{24.56}$	$\frac{114.0}{4.5}$
ILP-2	$\frac{68.3}{2.69}$	$\frac{617.5}{24.31}$	N/A	$\frac{114.0}{4.5}$

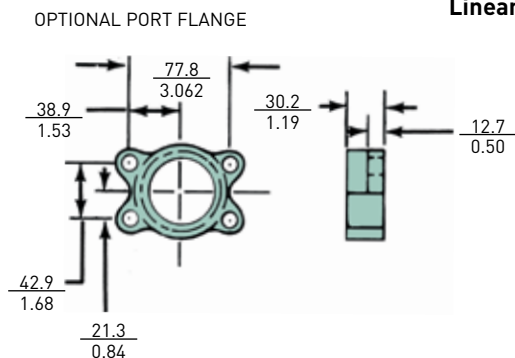
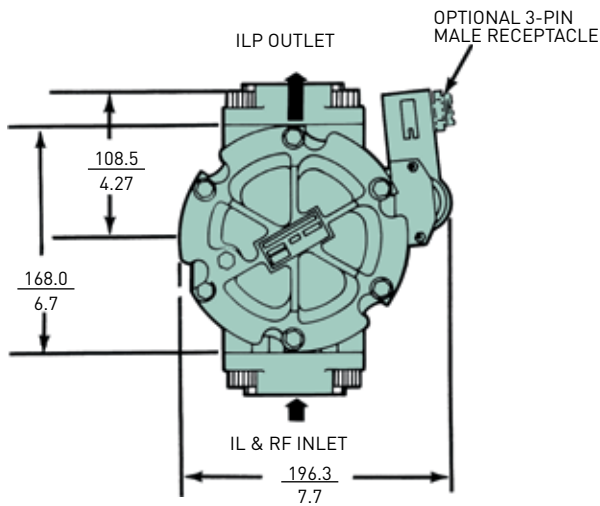

Linear Measure: millimeter
inch

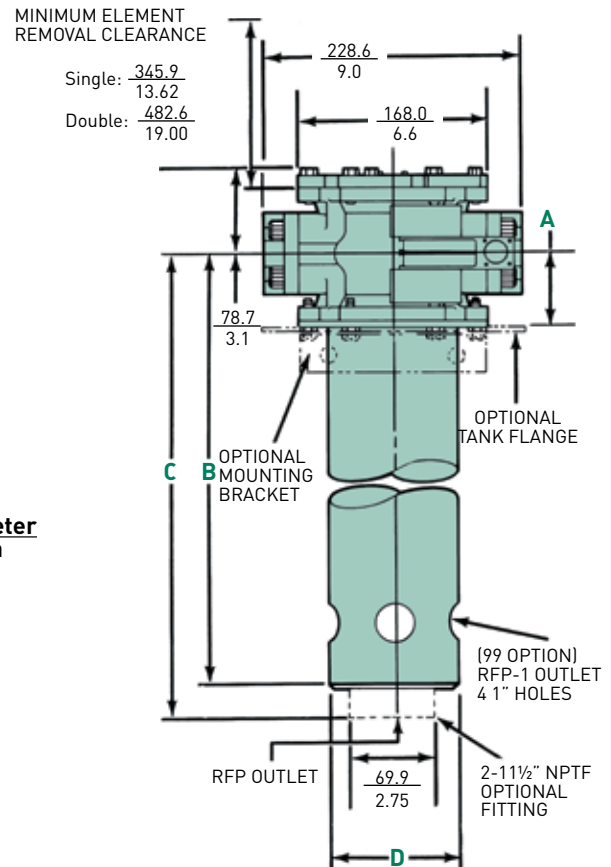

Specifications: DILP

Pressure Ratings:

Maximum Allowable Operating Pressure (MAOP): 200 psi (13.8 bar)
 Design Safety Factor: 2:1
 Rated Fatigue Pressure: 150 psi (10.3 bar)

Element Burst Rating: 70 psid (4.8 bar)

Filter Materials:

Diverter Valve Assembly: die cast aluminum
 Check Valve Assembly: die cast aluminum
 Filter Assembly: see IL2 specifications

Operating Temperatures:

Nitrile: -40°F to 225°F (-40°C to 107°C)
 Fluorocarbon: -15°F to 275°F (-26°C to 135°C)

Weight (approximate):

Single: 55 lbs. (24.9 kg) / Double: 65 lbs. (29.5 kg)

Indicators:

Visual (optional)
 Electrical (optional) 15A @ 250VAC / .5A @ 125 VDC
 Electrical ("D" option) 5A @ 250VAC / 3A @ 28 VDC

Color Coding:

White (normally closed)
 Red (normally open)
 Black (common)

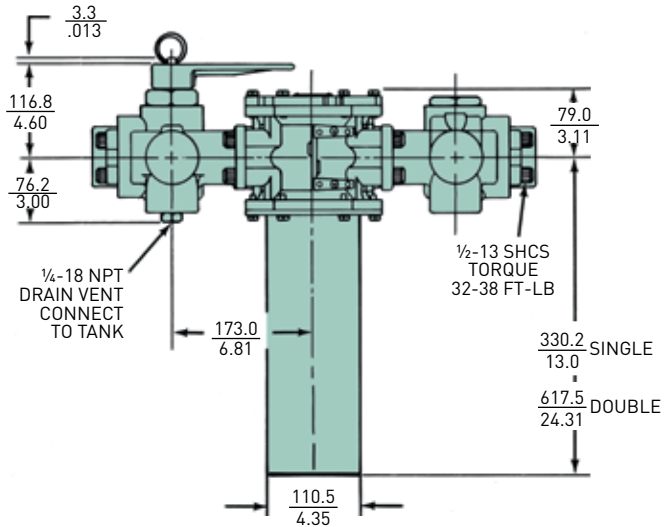
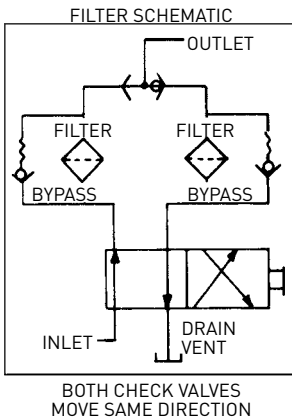

Linear Measure: millimeter
inch

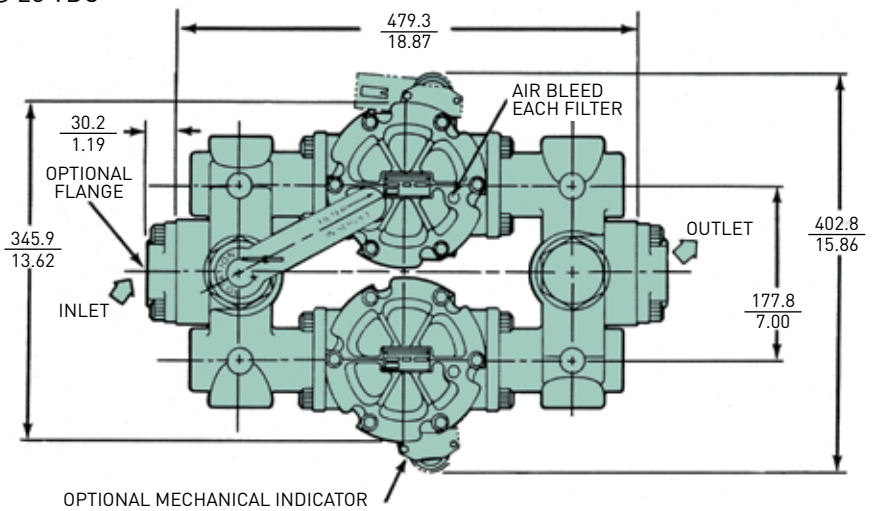

Approximate handle torque required for changeover.

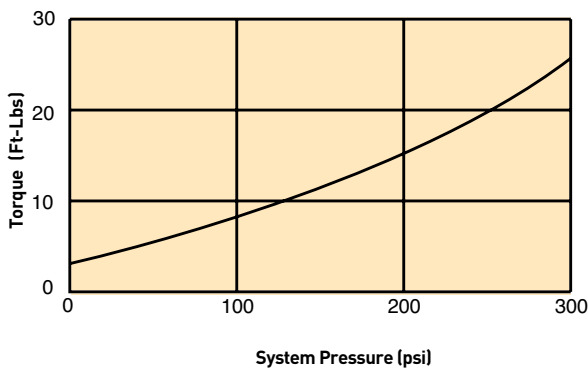

Typical Flow/Pressure Curves For Duplex Valves

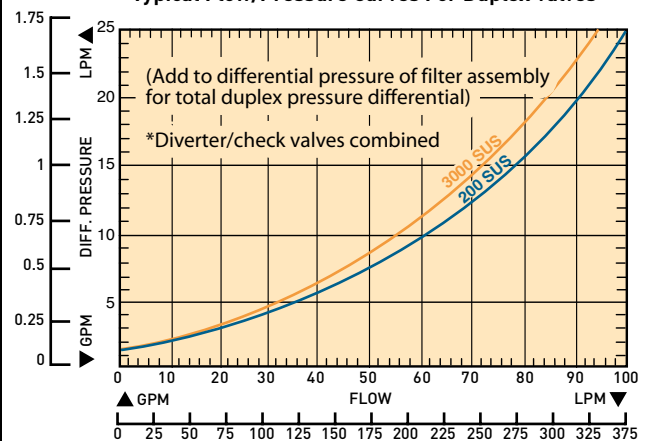

Low Pressure Filters

Moduflow™ Plus Series

For return line applications (RFP), the fluid returning to the reservoir holds the check valve open. When the system is shut down, the check valve closes automatically.

Check Valve Flow/Pressure Drop

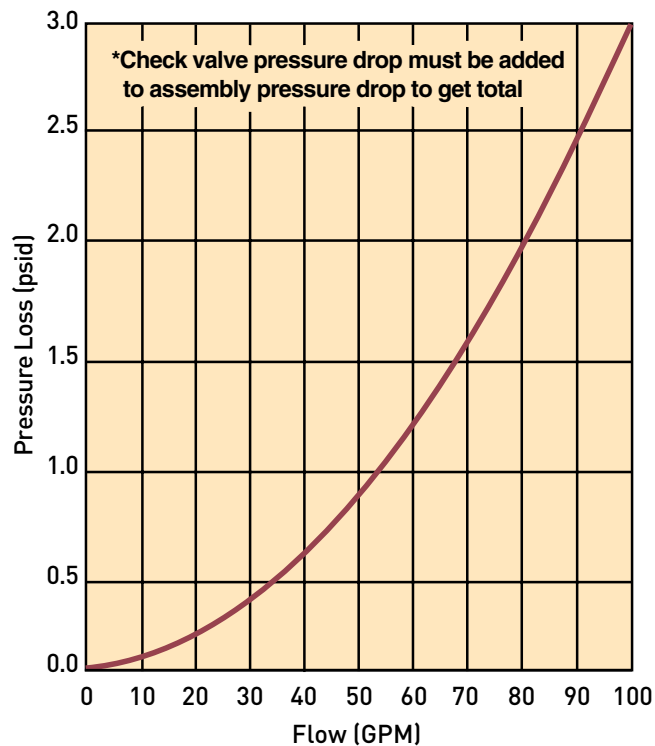

Linear Measure: $\frac{\text{millimeter}}{\text{inch}}$

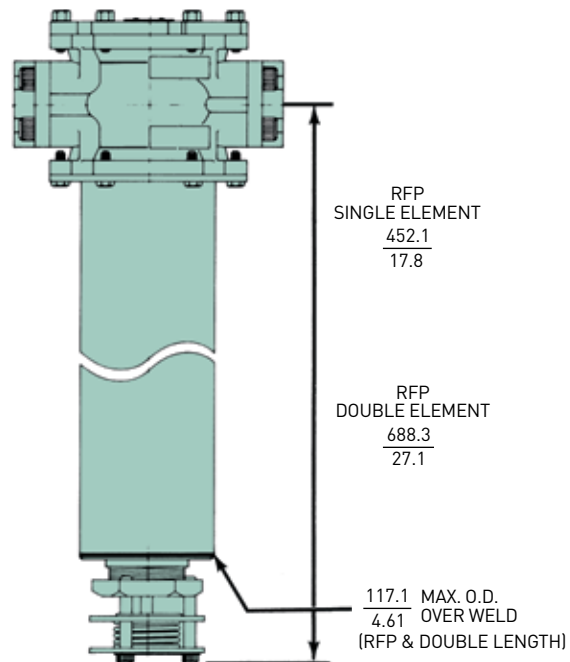

Accessories

Linear Measure: millimeter
inch

OPTIONAL MOUNTING BRACKET (924904)

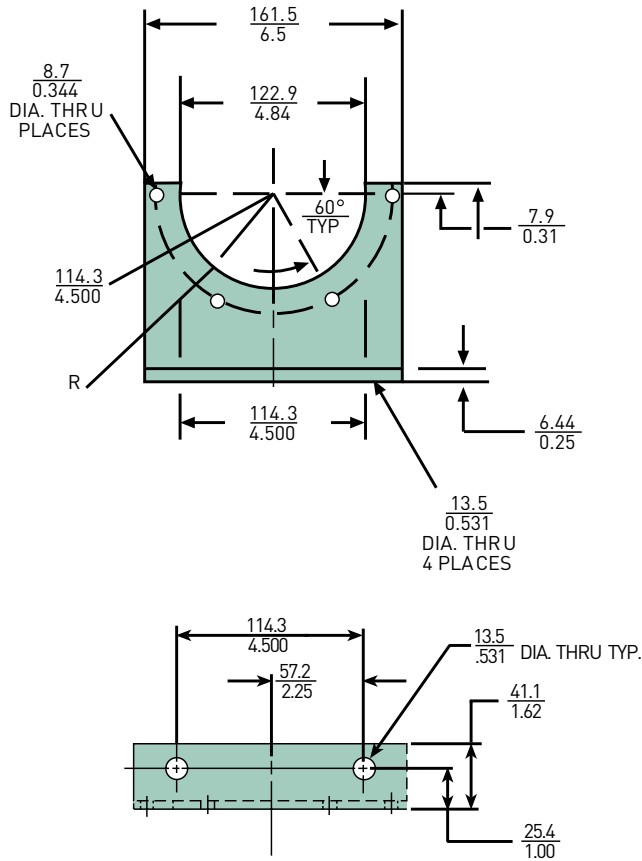

"M" OPTION-VISUAL INDICATOR,
NO ELEMENT WARNING



OPTIONAL TANK FLANGE (925167)

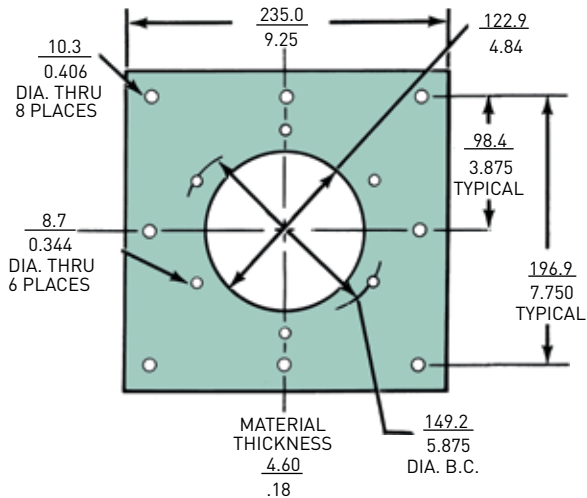

"E" OPTION-ELECTRICAL INDICATOR

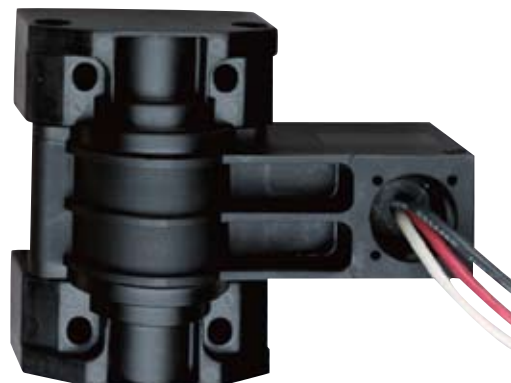

Low Pressure Filters

Moduflow™ Plus Series

Lower Cost than many single unit filters.

Moduflow™ Manifold Extended Filter Range

Use Model MM Manifold to handle return line flows up to 130 gpm.

- Rated static pressure: 300 psi
- Typical burst pressure: 900 psi
- Easily mounted on ModuFlow™

High Flows At Low Cost

The model MM manifold is designed to extend the flow range of ModuFlow™ Filters when operating with 10 Micron and finer filter media. When mounted to a pair of RFP-2 or ILP-2 filters, this manifold will allow flows up to 130 gpm in return lines (15 fps velocity).

Note: The Model MM manifold is not applicable to suction lines due to its pressure drop characteristics.

When used with two ModuFlow™ filters, the total cost is often less than a single unit filter rated for 130 gpm flow. Tank-top mounted (Model RFP) filters will require only one manifold on the filter inlet ports. In-line mounted (Model ILPav) filters will require two manifolds, one on the inlet and one on the outlet ports.

Multiple Uses

Although designed for manifold ModuFlow™ filters, the Model MM can be used in a variety of applications which require:

- Splitting flow between components

Such applications are frequently encountered on mobile equipment, machine tools, and large lubricating systems. In such applications, use of a manifold can often reduce total piping and installation costs.

Proven Reliability

The rugged design of the Model MM manifold has been proven in demanding mobil equipment applications. At the factory, we have cycle tested the Model MM through the full range of rated flow and pressure to insure reliable service.

Parker Filter Division maintains the same high standards in delivery, quality, and service. Considering this, plus features, flexibility, price, and performance, the Model MM manifold is a valuable addition to your fluid power component list.

FLOW/PRESSURE CURVE

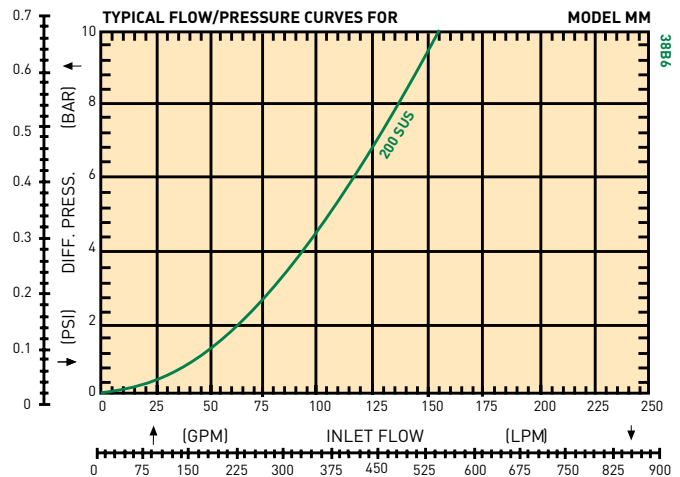

MANIFOLD SPECIFICATIONS

Rated Static Pressure, maximum:
20.7 bar (300 psi)

Typical Burst Pressure:
62.1 bar (900 psi)

Operating Temperature (Buna seals):
+121°C to -40°C (+250°F to 40°F)

Housing Material:
ANSI 356-T6 cast aluminum

Approximate Shipping Weight:
3.6 kg (8 lbs)

Porting: See Options Below

Order Screws and O-Rings Separately:

Inlet & outlet screws (12 required):

Order P/N 900228

Outlet port o-rings (2 required):

Nitrite: Order P/N N72228

Fluorocarbon: Order P/N V92228

HOW TO ORDER MANIFOLDS:

Part Number	Description
926466	Modulflow Manifold

- * Tank-top mounted RFP filters will require one manifold on filter inlets: in-line mounted ILP filters will require two manifolds on both inlets and outlets.

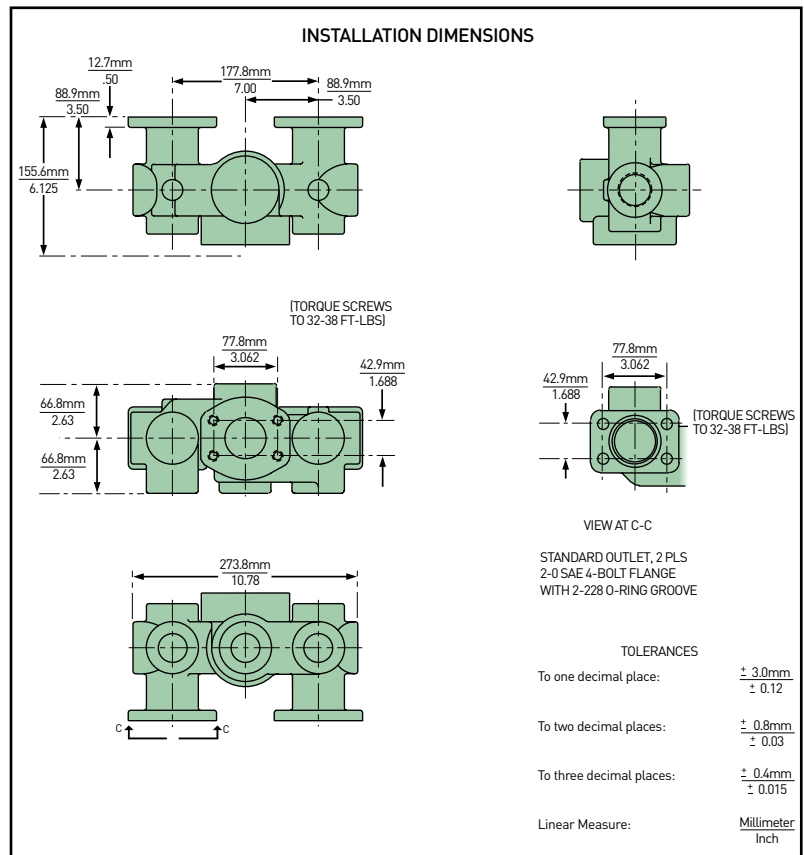

Low Pressure Filters

Moduflow™ Plus Series

Flange Kits (flange, 4 bolts, o-ring)

Size	Code	Part Number	
		Buna	Fluorocarbon
¾ inch NPTF	YB	924788	926013
1 inch NPTF	YC	924787	926012
1¼ inch NPTF	YD	924912	926004
1½ inch NPTF	YE	924786	926011
2 inch NPTF	YF	924785	926010
SAE - 12	YM	924784	926009
SAE - 16	YN	924783	926008
SAE - 20	YO	924913	926005
SAE - 24	YP	924782	926007
BLANK FLANGE	—	924782	926006

RFP/ILP/ DILP Replacement Elements

Media	Nitrile Seals				Fluorocarbon Seals			
	New Single	Replaces Old Single	New Double	Replaces Old Double	New Single	Replaces Old Single	New Double	Replaces Old Double
02Q	937393Q	932686Q	937397Q	932692Q	937401Q	932689Q	937405Q	932695Q
05Q	937394Q	932687Q	937398Q	932693Q	937402Q	932690Q	937406Q	932696Q
10Q	937395Q	932688Q	937399Q	932694Q	937403Q	932691Q	937407Q	932697Q
20Q	937396Q	933116Q	937400Q	933117Q	937404Q	933118Q	937408Q	933119Q

Parts List

Index	Description	Part No.	Quantity	Index	Description	Part No.	Quantity
1	Screws, Nameplate.....	900028	2	11	Check Valve Assy.	925120	1
2	Name Plate, Unstamped.....	920928	1	12	Flange Kits.....	Refer to Table	1
3	Cover Screws, 5/16-18 UNC x 1".....	926633	6	13	Plug Kit, Fastener, self-sealing, o-ring seal included with fastener	925974	2
4	Bowl Screws, 5/16-18 UNC x 1".....	926633	6	14	Indicator Electrical		Optional
5	Cover, Without nameplate.....	924634	1		35 psid.....	926643	
6	O-Ring, cover				35 psid, 3-pin male receptacle.....	926753	
	Nitrile.....	N72350	2	15	Indicator Visual		Optional
	Fluorocarbon.....	V72350	2		35 psid 4-band.....	926748	
7	Element Seal				Flange, In-tank mounting.....	925167	Optional
	Nitrile.....	937410	1		Bracket, Inline mounting.....	924904	Optional
	Fluorocarbon.....	937411	1		Indicator Kit, Remote mount.....	924894	Optional
8	Element.....	Refer to Table	1	16	Changeover Valve Assy., Duplex	926758	Optional
9	Head, Machined only.....		1	17	Check Valve Assy., Duplex.....	926757	Optional
	2" SAE Flange	925972	1	Not Shown	Drain Plug, SAE-24 for RFP model		
	1½" SAE Flange	926164	1		Nitrile.....	909992	1
	1½" NPTF	925949	1		Fluorocarbon.....	928363	1
10	Bowl, Select desired model		1				
	ILP-1.....	925916					
	ILP-2.....	924816					
	RFP-1.....	937626					
	RFP-1 with 2 inch NPTF fitting...	924676					
	RFP-2.....	937627					
	RFP-2 with 2 inch NPTF fitting...	924818					

Filter Assembly Exploded View

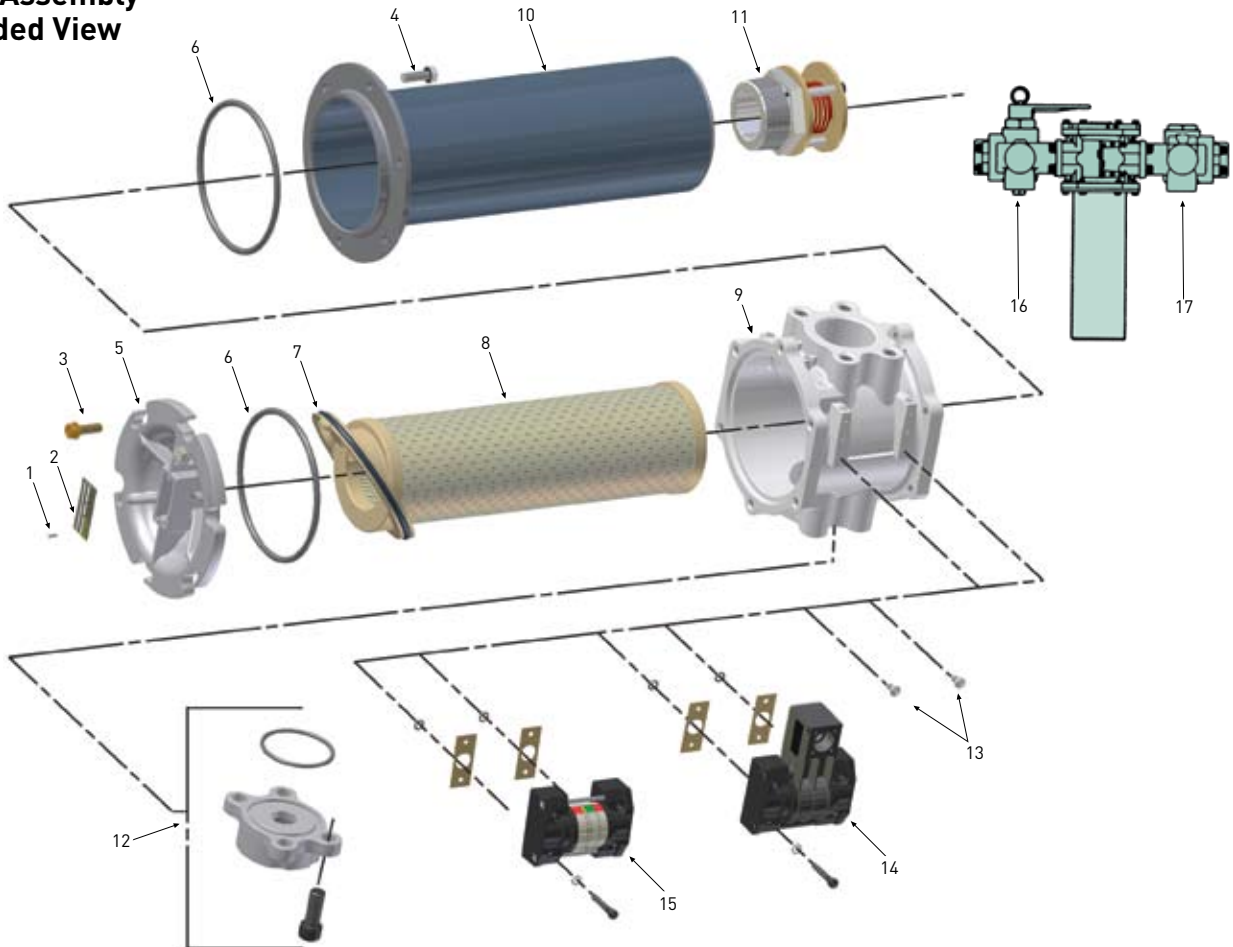

Low Pressure Filters

Moduflow™ Plus Series

HOW TO ORDER: Select the desired symbol (in the correct position) to construct a model code.

Example:

BOX 1	BOX 2	BOX 3	BOX 4	BOX 5	BOX 6	BOX 7	BOX 8
ILP	1	10Q	B	MP	35	Y9Y9	1

BOX 1: Filter Series Symbol		Description
RFP		Return-line filter, inlet on side outlet on bottom
ILP		In-line filter
DILP		In-line duplex

BOX 2: Element Length Symbol		Description
1		Single
2		Double

BOX 3: Media Code Symbol		Description
02Q		Microglass III, 2 micron
05Q		Microglass III, 5 micron
10Q		Microglass III, 10 micron
20Q		Microglass III, 20 micron
WR		Water Removal

BOX 4: Seals Symbol		Description
B		Nitrile
E		EPR
V		Fluorocarbon

BOX 5: Indicator Symbol		Description
P		Pressure ports drilled & plugged only; no indicator
M		Visual indicator w/"no element" warning
E		Electrical indicator only
D		Electrical indicator only, 3-pin male receptacle

Note: First letter of indicator code = left side of filter head when looking into inlet with bowl down; second letter = right side of filter head when looking into inlet with bowl down.

BOX 6: Bypass Setting Symbol		Description
35		35 psid

BOX 7: Port Options			
Filter Model	Inlet Symbol/Description	Outlet Symbol/Description	
RFP	Y9 2" flange face	99 No fitting	
	P9 SAE-24 integral threads	F9 2" NPTF	
	E9 1½ NPTF integral threads	F8 External check valve	
ILP	Y9 2" flange face	99 No fitting	
	P9 SAE-24 integral threads	P9 SAE-24 integral threads	
	E9 1½ NPTF integral threads	E9 1½ NPTF integral threads	
DILP	Y9 2" flange face	Y9 2" flange face	

- 1) First pair of symbols denotes inlet for all filter styles; second pair of symbols denotes outlet.
- 2) Four symbols required: two for inlet, two for outlet.
- 3) Unused ports in filters come plugged with a blank flange.
- 4) See Flange Kits table for port flange options. Flange Kits are ordered separately.

BOX 8: Options Symbol		Description
1		None