

C-3005

Fulflo® “M” Series Single Cartridge Vessels

Fulflo® High-Pressure Single Cartridge

Parker’s “M” Series Single Cartridge Filter Vessels are designed for a broad range of high pressure industrial and chemical process applications. All details of design, materials, construction and workmanship comply with the ASME code for pressure vessels. The “M” series is available with and without the ASME stamp.

Benefits

- ASME design to insure integrity, available with and without the ASME stamp
- T-Style head and shell for ease of installation and servicing
- Standard O-Ring closure seal is Buna N, with optional materials available for improved chemical compatibility and higher temperature rating
- Flanged or threaded connections to suit installation requirements and preference
- Optional 150, 300 or 600 lb. RFSO flange connections for installation flexibility
- 1-inch connections for maximum flow capability of filter cartridges
- Utilizes one 10-, 20- or 30-inch cartridge
- Multiple bolt closure with bright zinc plated studs



- Optional single-open-end (SOE 2-222 TC Style) cartridge adapter for positive sealing of high efficiency filter cartridges
- Wide range of cartridge media available for process clarity control and chemical compatibility
- Rigid cartridge support post with threaded end seal for positive double open end (DOE) cartridge seating

Applications

- Chemicals
- Catalyst Recovery
- Solvents
- Cutting Oils
- Other High Pressure Liquids
- Process Water
- Lubricants
- Coolants
- Hydraulic Oils
- Compressed Air and Gases



ENGINEERING **YOUR** SUCCESS.

Fulflo® “M” Series Single Cartridge Vessels

Specifications

Carbon steel or 316 stainless steel material
 Drain: 1/4 in NPT
 Vent: 1/4 in NPT
 Bolting: (4) 5/8-11 UNC bright zinc plated carbon steel
 Head to shell seal

Maximum Allowable Working Pressure

| Connections | Designation | Carbon Steel at 250°(121°C) | 316 Stainless Steel at 250°(121°C) |
|----------------|-------------|-----------------------------|------------------------------------|
| FNPT | T | 1610 psig | 1610 psig |
| 150 lb. Flange | F | 245 psig | 225 psig |
| 300 lb. Flange | H | 665 psig | 590 psig |
| 600 lb. Flange | J | 1332 psig | 1180 psig |

Note: FNPT maximum pressure is 1610 psig at 300°F with EPR O-ring, 400°F with Viton* and FEP encapsulated Viton* O-ring, and 500°F with FEP Encapsulated Silicone. Flanged units (F, H, and J designations) are based on ANSI B16.5 pressure at 250°F (121°C). The flanged versions can also be rated for the higher design temperature in which case the pressure rating will be reduced according to ANSI B16.5. Indicate the desired temperature in degrees F at the end of the model number. The gasket material and flange rating must be changed accordingly.

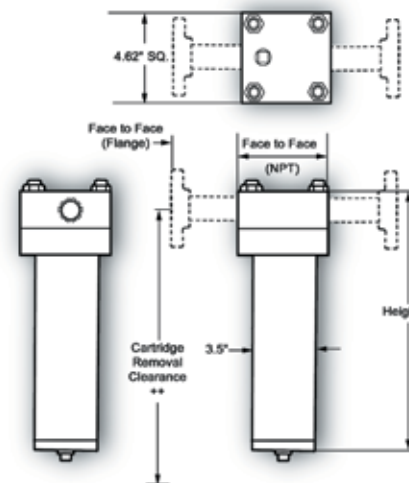

“M” Series Flow Rates and Dimensions

| Model | Typical Aqueous† Flow Rate (gpm) | Cartridge Length (in) | Cartridge Height (in)++ | Inlet Face to Outlet Face (in) | | Removal Weight (lbs) | | Removal Clearance (in)++ |
|--------------|-------------------------------------|--------------------------|----------------------------|-----------------------------------|---------|-------------------------|---------|-----------------------------|
| | | | | FNPT | Flanged | FNPT | Flanged | |
| | | | | MC(N or U)1S | 6 | 10 | 14.5 | |
| MC(N or U)1D | 12 | 20 | 24.5 | 4.62 | 12.62 | 46 | 54 | 42 |
| MC(N or U)1T | 18 | 30 | 34.5 | 4.62 | 12.62 | 55 | 63 | 62 |

† Actual flow is dependent on fluid viscosity, micron rating, contaminant, media type and desired initial pressure drop.

++ Add 3” when using TC internal option for use with TC style 2-222 O-ring cartridges.

Ordering Information

M

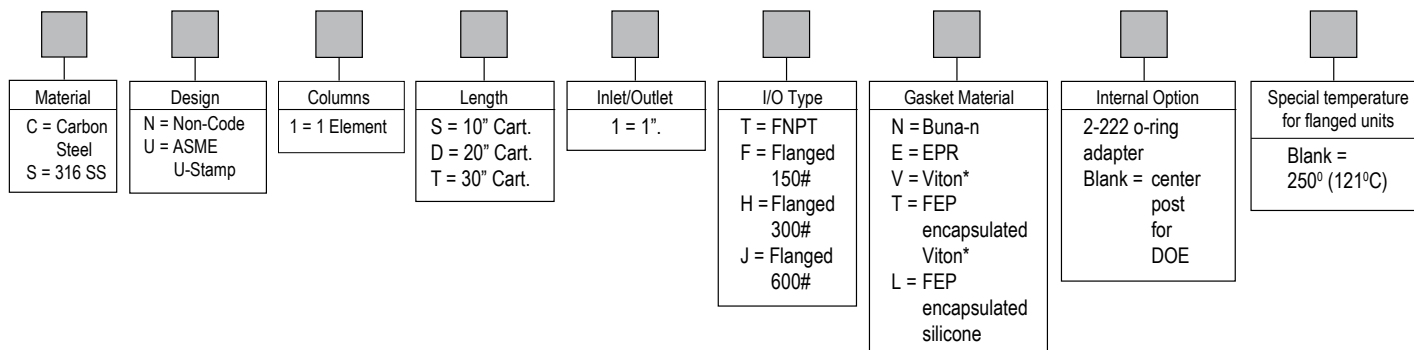

Specifications are subject to change without notification.
 *Viton is a registered trademark of E.I. DuPont de Nemours & Co., Inc.

© 2007 Parker Hannifin
 Process Advanced Filtration Inc.
 All Rights Reserved
 SPEC-C3005-Rev. A 01/08



ENGINEERING YOUR SUCCESS.