

C-3070

## Fulflo® S Filter Vessels

### Fulflo® S Series ASME Code Filter Vessels

Fulflo® S Series Multi-Cartridge Filter Vessels meet a broad range of liquid and gas applications for flow rates up to 2,040 gpm (7,720 lpm). All details of design, materials, construction and workmanship of the S vessel series conform to ASME code.

The S Vessel Series accommodates double-open-end (DOE) or single-open-end (SOE) filter cartridges in 10 in, 20 in, 30 in and 40 in equivalents.

### Benefits

- Built in accordance with ASME boiler and pressure vessel code
- Available in 150 psi (10.3 bar) and 300 psi (20.7 bar) designs
- Non-code design and construction (parallel to code standards) available
- Mechanical coverlifts standard on most models
- S85 and S102 feature hydraulic coverlifts (available on all models as an option)
- Dual purpose cartridge seats for use with double open end and 2-222 O-ring single open end cartridges



- Buna-N O-ring closure seal provides positive cover sealing.
- Viton\* elastomer, neoprene, ethylene propylene rubber and fluoropolymer elastomer O-rings are also available for temperatures up to 500°F (261°C)
- All S models feature swing bolts with closures for quick cleaning and servicing
- Accepts double-open-end (DOE) or single-open-end (SOE) cartridges

### Applications

- Liquid
- Gas
- Food & Beverage
- Chemical Processes
- Petrochemical
- Paints & Coatings
- Industrial



ENGINEERING **YOUR** SUCCESS.

# Fulflo® S Filter Vessels

## 150 psi (10.3 bar) Design Specifications

No. & Model	Length of Cartridges (in)	Maximum Flow (gpm)	Dimensions								Shipping J††	Weight (lbs)
			A†	B	C	D	E	F	G	H		
S25-3-4F	(25) 30	375	55.88	26.00	18.06	15.50	28	5	20.44	17.76	4	515
S25-4-6F	(25) 40	500	69.75	26.00	18.06	16.50	31	5	22.25	17.76	6	540
S35-3-4F	(35) 30	525	58.19	29.25	20.06	16.50	31	5	22.56	19.77	4	640
S35-3-6F	(35) 30	525	58.19	29.25	20.06	16.50	31	5	22.56	19.77	6	645
S35-4-6F	(35) 40	700	68.25	29.25	20.06	16.50	31	5	22.56	19.77	6	695
S40-3-6F	(40) 30	600	60.25	30.75	22.06	18.00	32	5	23.31	21.70	6	810
S52-3-4F	(52) 30	780	63.69	33.38	24.06	20.50	34	5	27.56	23.72	4	855
S52-3-6F	(52) 30	780	63.69	33.38	24.06	20.50	34	5	27.56	23.72	6	865
S52-4-8F	(52) 40	1040	73.69	33.38	24.06	20.50	34	5	27.56	23.72	6	900
S85-3-8F	(85) 30	1275	67.25	39.75	30.06	24.00	40	6	31.50	29.81	8	1170
S85-4-8F	(85) 40	1700	73.63	39.75	30.06	24.00	40	6	31.50	29.81	8	1200
S102-3-8F	(102) 30	1530	68.63	42.25	32.06	23.63	41.25	6	31.69	31.81	8	1450
S102-4-8F	(102) 40	2040	79.94	42.25	32.06	23.63	41.25	6	31.69	31.81	8	1600

† Add 5 in to this dimension for hydraulic coverlift.

†† Inlet and outlet size standard ASA flanges.

## Maximum Operating Conditions

Material of Construction	Maximum Operating Pressure (psi at 250°F) †	Maximum Design Temperature
Carbon Steel	150 psi (10.3 bar)	500°F (260°C)
Carbon Steel	300 psi (20.7 bar)	500°F (260°C)
304 Stainless Steel	150 psi (10.3 bar)	300°F (150°C)
304 Stainless Steel	300 psi (20.7 bar)	300°F (150°C)
316 Stainless Steel	150 psi (10.3 bar)	400°F (204°C)
316 Stainless Steel	300 psi (20.7 bar)	400°F (204°C)

† Operating temperature limited by standard gasket material and exterior paint.

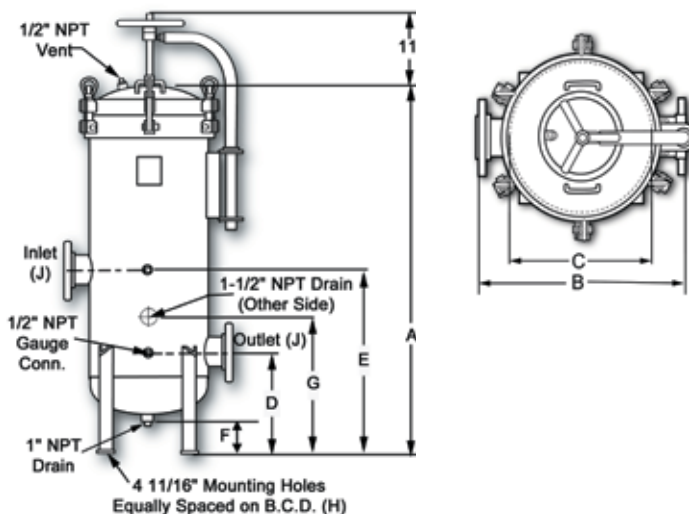

## Ordering Information

□	□	□	□	□	□
<b>Material</b>	<b>Design Series</b>	<b>Number of Columns</b>	<b>Cartridge Length (in)</b>	<b>Inlet/Outlet Flange Size</b>	<b>Coverlift Option</b>
No Symbol = Carbon Steel 4 = 304 Stainless Steel 6 = 316 Stainless Steel	HS = High Pressure CS = Non-Code	25 35 40 52 85 102	3 30 4 = 40	4F = 4 in Flange 6F = 6 in Flange 8F = 8 in Flange	K1= Mechanical K2 = Hydraulic

Specifications are subject to change without notification.  
\*Viton is a registered trademark of E.I. DuPont de Nemours & Co., Inc.

© 2007 Parker Hannifin  
Process Advanced Filtration Inc.  
All Rights Reserved  
SPEC-C3070-Rev. A 01/08



ENGINEERING **YOUR** SUCCESS.